

# Service Manual

## **MF3110 Series** **LaserBase MF3110**

**Canon**

Aug 27 2004



## Application

This manual has been issued by Canon Inc. for qualified persons to learn technical theory, installation, maintenance, and repair of products. This manual covers all localities where the products are sold. For this reason, there may be information in this manual that does not apply to your locality.

## Corrections

This manual may contain technical inaccuracies or typographical errors due to improvements or changes in products. When changes occur in applicable products or in the contents of this manual, Canon will release technical information as the need arises. In the event of major changes in the contents of this manual over a long or short period, Canon will issue a new edition of this manual.

The following paragraph does not apply to any countries where such provisions are inconsistent with local law.

## Trademarks

The product names and company names used in this manual are the registered trademarks of the individual companies.

## Copyright

This manual is copyrighted with all rights reserved. Under the copyright laws, this manual may not be copied, reproduced or translated into another language, in whole or in part, without the written consent of Canon Inc.

***COPYRIGHT © 2001 CANON INC.***

*Printed in Japan*

## Caution









Use of this manual should be strictly supervised to avoid disclosure of confidential information.

---

## Symbols Used



---

This documentation uses the following symbols to indicate special information:

Symbol	Description
	Indicates an item of a non-specific nature, possibly classified as Note, Caution, or Warning.
	Indicates an item requiring care to avoid electric shocks.
	Indicates an item requiring care to avoid combustion (fire).
	Indicates an item prohibiting disassembly to avoid electric shocks or problems.
	Indicates an item requiring disconnection of the power plug from the electric outlet.
 Memo	Indicates an item intended to provide notes assisting the understanding of the topic in question.
 REF.	Indicates an item of reference assisting the understanding of the topic in question.
	Provides a description of a service mode.
	Provides a description of the nature of an error indication.

The following rules apply throughout this Service Manual:

1. Each chapter contains sections explaining the purpose of specific functions and the relationship between electrical and mechanical systems with reference to the timing of operation.

In the diagrams,  represents the path of mechanical drive; where a signal name accompanies the symbol, the arrow  indicates the direction of the electric signal.

The expression "turn on the power" means flipping on the power switch, closing the front door, and closing the delivery unit door, which results in supplying the machine with power.

2. In the digital circuits, '1' is used to indicate that the voltage level of a given signal is "High", while '0' is used to indicate "Low". (The voltage value, however, differs from circuit to circuit.) In addition, the asterisk (\*) as in "DRMD\*" indicates that the DRMD signal goes on when '0'.

In practically all cases, the internal mechanisms of a microprocessor cannot be checked in the field. Therefore, the operations of the microprocessors used in the machines are not discussed: they are explained in terms of from sensors to the input of the DC controller PCB and from the output of the DC controller PCB to the loads.

The descriptions in this Service Manual are subject to change without notice for product improvement or other purposes, and major changes will be communicated in the form of Service Information bulletins.

All service persons are expected to have a good understanding of the contents of this Service Manual and all relevant Service Information bulletins and be able to identify and isolate faults in the machine."



---



---

# Contents

## Chapter 1 PRODUCT DESCRIPTION

1.1 Product Specifications .....	1- 1
1.1.1 Product Specifications .....	1- 1
1.2 Detailed Specifications .....	1- 3
1.2.1 Printing Speed .....	1- 3
1.2.2 Stack Upon Delivery .....	1- 3
1.2.3 System Requirements for Printer Driver .....	1- 4
1.3 Names of Parts .....	1- 5
1.3.1 External View .....	1- 5
1.3.2 Operation panel .....	1- 7
1.4 Safety .....	1- 8
1.4.1 Safety of Laser Light .....	1- 8
1.4.2 Handling the Laser Unit .....	1- 8
1.4.3 Safety of Toner .....	1- 9

## Chapter 2 TECHNICAL REFERENCE

2.1 Document Feed and Exposure System .....	2- 1
2.1.1 Overview/Configuration .....	2- 1
2.2 Laser Exposure .....	2- 2
2.2.1 Overview/Configuration .....	2- 2
2.3 Image Formation .....	2- 4
2.3.1 Overview/Configuration .....	2- 4
2.4 Pickup and Feed System .....	2- 6
2.4.1 Overview/Configuration .....	2- 6
2.4.2 Detection Jams .....	2- 7
2.5 Fixing Unit .....	2- 9
2.5.1 Overview/Configuration .....	2- 9
2.5.2 Protective Function .....	2- 10
2.6 External and Controls .....	2- 12
2.6.1 Power Supply .....	2- 12

## Chapter 3 DISASSEMBLY AND ASSEMBLY

3.1 EXTERNAL AND CONTROLS SYSTEM .....	3- 1
3.1.1 Front Cover .....	3- 1
3.1.2 Rear Cover .....	3- 1
3.1.3 Top Cover .....	3- 2
3.1.4 Right Cover .....	3- 4
3.1.5 Left Cover .....	3- 4
3.1.6 Operation Panel Unit .....	3- 5
3.1.7 SCNT Board .....	3- 7
3.1.8 ECNT Board .....	3- 9

3.1.9 Power Supply PCB .....	3- 10
3.1.10 High-voltage Power Supply PCB.....	3- 12
3.1.11 Top Sensor.....	3- 14
3.1.12 Paper Delivery Sensor.....	3- 17
3.2 Document Feed/Exposure System.....	3- 21
3.2.1 Scanner Unit.....	3- 21
3.2.2 Scanner Cover Unit.....	3- 22
3.2.3 CCD Unit.....	3- 25
3.2.4 Flatbed Motor Unit.....	3- 28
3.3 LASER EXPOSURE SYSTEM .....	3- 31
3.3.1 Laser/Scanner Unit.....	3- 31
3.4 IMAGE FORMATION SYSTEM.....	3- 34
3.4.1 Transfer Charging Roller .....	3- 34
3.5 PICKUP AND FEEDING SYSTEM.....	3- 35
3.5.1 Cassette Pickup Roller .....	3- 35
3.5.2 Cassette Pickup Solenoid .....	3- 39
3.5.3 Cassette Separation Pad .....	3- 42
3.5.4 Paper Feed Roller .....	3- 43
3.5.5 Manual Pickup Solenoid .....	3- 48
3.5.6 Main Motor .....	3- 51
3.5.7 Gear Unit.....	3- 55
3.6 FIXING SYSTEM.....	3- 56

## Chapter 4 MAINTENANCE AND INSPECTION

4.1 Periodically Replaced Parts .....	4- 1
4.1.1Parts Requiring Periodical Replacement .....	4- 1
4.2 Consumables.....	4- 2
4.2.1Consumable .....	4- 2
4.3 Periodical Service .....	4- 3
4.3.1Items Requiring Scheduled Servicing .....	4- 3
4.4 Cleaning .....	4- 4
4.4.1Items Requiring Cleaning .....	4- 4
4.4.2Cleaning Method (external covers) .....	4- 5
4.4.3Cleaning Method (scanning unit) .....	4- 5
4.4.4Cleaning Method (printer unit).....	4- 6
4.5 Lubrications .....	4- 8
4.5.1Areas Requiring Application of Grease.....	4- 8
4.5.2Delivery Idler Gear .....	4- 9
4.5.3Fixing Drive Transmission Gear .....	4- 10
4.5.4Large Gear Bushing R .....	4- 10
4.5.5Large Gear .....	4- 11
4.5.6Feed Gear.....	4- 11
4.5.7Internal Gear .....	4- 12
4.5.8Large Gear Deceleration Gear/Plate R .....	4- 12
4.5.9Main Motor.....	4- 13
4.5.10Drive Releasing Arm .....	4- 14
4.5.11FU Delivery Roller .....	4- 14
4.5.12Pickup Idler Gear.....	4- 15



4.5.13 Feed Deceleration Gear .....	4- 15
4.5.14 Fixing Deceleration Gear .....	4- 16
4.5.15 FD Delivery Roller .....	4- 17
4.5.16 Large Gear Bushing F .....	4- 17
4.5.17 Pressure roller .....	4- 18
4.5.18 Cassette Pickup Roller .....	4- 18
4.5.19 CCD Shaft .....	4- 19
4.5.20 Wheel Shaft .....	4- 19

## Chapter 5 TROUBLE-SHOOTING

5.1 Phenomenon Table .....	5- 1
5.1.1 Symptoms .....	5- 1
5.2 Countermeasure .....	5- 2
5.2.1 Image Faults .....	5- 2
5.2.2 Malfunction .....	5- 2
5.2.3 Printing/Scanning .....	5- 3
5.2.4 Jam (Main Unit) .....	5- 3
5.3 Measurement and Adjustment .....	5- 4
5.3.1 Basic Adjustments .....	5- 4
5.4 Service Tools .....	5- 5
5.4.1 Special Tools .....	5- 5
5.5 Error Code .....	5- 6
5.5.1 Outline .....	5- 6
5.5.2 Service Error Code .....	5- 6
5.6 Service Mode .....	5- 8
5.6.1 Outline .....	5- 8
5.6.2 Service Soft Switch Settings (SSSW) .....	5- 12
5.6.3 ROM Management (ROM) .....	5- 14
5.6.4 Test Mode (TEST) .....	5- 14

## Chapter 6 APPENDIX

6.1 Outline of Electrical Components .....	6- 1
6.1.1 Sensor .....	6- 1
6.1.2 PCBs .....	6- 2



---

# Chapter 1    PRODUCT                   DESCRIPTION

---



# Contents

1.1 Product Specifications .....	1- 1
1.1.1Product Specifications .....	1- 1
1.2 Detailed Specifications .....	1- 3
1.2.1Printing Speed .....	1- 3
1.2.2Stack Upon Delivery .....	1- 3
1.2.3System Requirements for Printer Driver .....	1- 4
1.3 Names of Parts.....	1- 5
1.3.1External View .....	1- 5
1.3.2Operation panel .....	1- 7
1.4 Safety .....	1- 8
1.4.1Safety of Laser Light.....	1- 8
1.4.2Handling the Laser Unit .....	1- 8
1.4.3Safety of Toner.....	1- 9



# 1.1 Product Specifications

## 1.1.1 Product Specifications

0007-7055

<b>Body installation method</b>	Desktop
<b>Exposure Method</b>	Semi-conductor laser
<b>Development Method</b>	Toner projection
<b>Transfer Method</b>	Roller transfer
<b>Fixing method</b>	On-demand fixing
<b>Delivery method</b>	Facedown /Faceup
<b>Toner level detection function</b>	None
<b>Toner supply type</b>	Toner cartridge replacement / Cartridge EP-27
<b>Document type</b>	Sheet, 3D object (up to 2kg)
<b>Maximum document size</b>	216 x 297 mm
<b>Scanning method</b>	CCD scanning method
<b>Reproduction ratio</b>	1:1+/-1.0 %, 1:2.000, 1:1.294, 1:0.786, 1:0.647, 1:0.500 / Zoom: 0.500 to 2.000 (unit: 1 %)
<b>Print area</b>	Print: 5 mm and more inner from paper edges/ Copy: 2 mm and more inner from paper edges
<b>Reading resolution</b>	1200 x 2400 dpi
<b>Copying resolution</b>	600 x 600 dpi
<b>Printing resolution</b>	1200 x 600 dpi
<b>Print speed (A4)</b>	approx. 20 sheets/min
<b>Print speed(LTR)</b>	approx. 21 sheets/min
<b>Warm-up Time</b>	Approx. 260 sec. (temperature: 20 deg C, humidity: 65%; from when the machine is plugged in untill the standby display appears) : Warm-up time may differ depending on the condition and environment of the machine.
<b>First Print Time</b>	approx. 13.8 sec.
<b>Cassette paper size</b>	A4, B5, A5, Letter, Legal, Executive
<b>Multi-purpose paper size</b>	A4, B5, A5, Letter, Legal, Executive, Envelope (DL, ISO-C5, COM10, MONARCH)

<b>Cassette paper type</b>	Plain paper (64 to 90 g/m <sup>2</sup> ), Heavy paper (91 to 128 g/m <sup>2</sup> ), Transparency
<b>Multi-purpose paper type</b>	Plain paper (64 to 90 g/m <sup>2</sup> ), Heavy paper (91 to 163 g/m <sup>2</sup> ), Transparency, Envelope (DL, ISO-C5, COM10, MONARCH)
<b>Cassette capacity</b>	Plain paper (64, 75, 80 g/m <sup>2</sup> ): approx. 250 sheets, Heavy paper (90, 105 g/m <sup>2</sup> ): approx. 200 sheets, Heavy paper H (128 g/m <sup>2</sup> ): approx. 100 sheets, Transparency: approx. 100 sheets, Envelope: approx. 20 sheets
<b>Multi-purpose capacity</b>	1 sheet
<b>Continuous reproduction</b>	99 sheets
<b>Energy save mode</b>	Yes
<b>Operating environment (Temperature range)</b>	15 to 32.5 deg C
<b>Operating environment (Humidity range)</b>	20 to 80 %RH
<b>Power supply rating</b>	200-240V, 50-60Hz
<b>Power consumption (Maximum)</b>	approx. 700 W
<b>Dimensions</b>	449 mm x 462 mm x 369 mm
<b>Weight</b>	approx. 12 kg (including cartridge)
<b>Option</b>	None



## 1.2 Detailed Specifications

### 1.2.1 Printing Speed

0007-7946

T-1-1

Paper size	Fixing mode						
	Plain paper	Plain paper L	Heavy paper	Heavy paper H	Transparency	Envelope	COM10
A4 ( to 64 g/m2)	20	20	20	12	20	-	-
A4 (65 to 90 g/m2)	-	18	10	8	18	-	-
B5 (64 to 90 g/m2)	8	8	4	4	8	-	-
A5 (64 to 90 g/m2)	8	8	4	4	8	-	-
A4 (105 to 128 g/m2)	-	-	18	12	-	-	-
B5 (105 to 128 g/m2)	-	-	4	4	-	-	-
LTR (75 to 90 g/m2)	21	21	21	12	21	-	-
LGL (75 to 90 g/m2)	15	-	-	-	-	-	-
LTR (Bond 75 to 90 g/m2, 105 g/m2)	-	-	21	12	-	-	-
Envelope	-	-	-	-	-	4	4

(unit: sheets/min)

### 1.2.2 Stack Upon Delivery

0007-6394

T-1-2

Paper type	Face-down	Face-up
Plain paper (64 to 75 g/m2)	Approx. 60 sheets	1 sheet
Heavy paper (91 to 128 g/m2)	Approx. 30 sheets	1 sheet
Transparency	Approx. 10 sheets	1 sheet
Label	-	1 sheet
Envelope	Approx. 10 sheets	1 sheet

 The values herein are estimates only and are subject to change for product improvement.

### 1.2.3 System Requirements for Printer Driver

0007-8001

#### Operating System

Windows 98, Windows Me, Windows 2000 Professional, Windows XP

#### Computer

Any computer on which Windows 98, Windows Me, Windows 2000, or Windows XP runs properly.

#### Hardware Environment

- IBM or IBM-compatible PC
- CD-ROM drive or network environment with the access to CD-ROM
- PC equipped with a USB port and the USB class driver installed

T-1-3

OS	CPU	RAM	Available Free Disk Space
Windows 98	Intel Pentium 90 MHz or greater	32 MB of RAM, 64 MB or greater is recommended	At least 115 MB, 200MB or greater is recommended
Windows Me	Intel Pentium 150 MHz or greater	32 MB of RAM, 64 MB or greater is recommended	At least 115 MB, 200MB or greater is recommended
Windows 2000* Professional	Intel Pentium 133 MHz or greater, or compatible micro processors (up to 2 processors are supported)	64 MB of RAM, 128 MB or greater is recommended	At least 115 MB, 200MB or greater is recommended
Windows XP*	Pentium Family 300 MHz or greater	64 MB of RAM, 128 MB or greater is recommended	At least 115 MB, 200MB or greater is recommended

\*Log on as a user with administrator privileges is recommended.

---

## 1.3 Names of Parts

---

### 1.3.1 External View

0007-6429

<Front View>

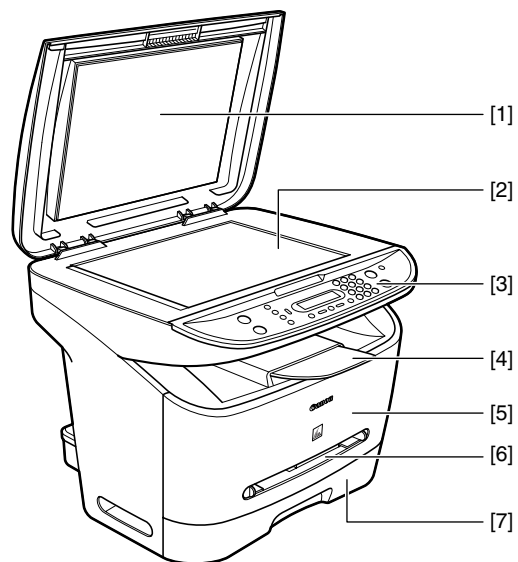

F-1-1

T-1-4

[1] Platen glass cover

[2] Platen glass

[3] Operation panel

[4] Output tray

[5] Front cover

[6] Multi-purpose feeder

[7] Cassette

<Rear View>

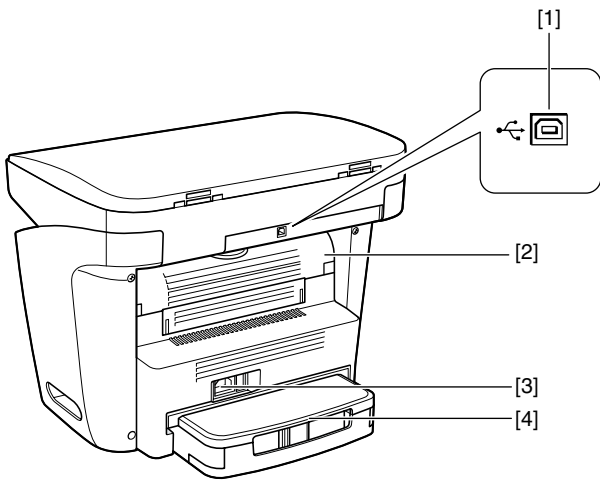

F-1-2

T-1-5

- [1] USB port
- [2] Face up cover
- [3] Power socket
- [4] Extension cover

## 1.3.2 Operation panel

0007-6441

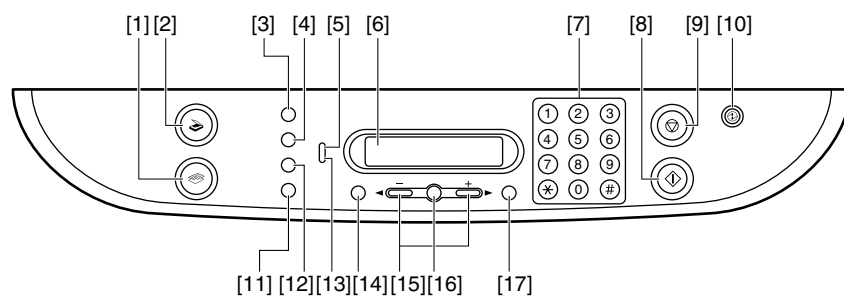

F-1-3

T-1-6

- |                        |                         |
|------------------------|-------------------------|
| [1] COPY key           | [10] Energy Saver key   |
| [2] SCAN key           | [11] Collate/2on1 key   |
| [3] Enlarge/Reduce key | [12] Image Quality key  |
| [4] Exposure key       | [13] Memory indicator   |
| [5] Alarm indicator    | [14] Menu key           |
| [6] LCD                | [15] Cursor keys        |
| [7] Numeric keys       | [16] OK key             |
| [8] Start key          | [17] Status Monitor key |
| [9] Stop/Reset key     |                         |

## 1.4 Safety

---

### 1.4.1 Safety of Laser Light

0002-8615

Laser radiation could be hazardous to the human body. For this reason, laser radiation emitted inside this machine is hermetically sealed within the protective housing and external cover. No radiation can leak from the machine in the normal operation of the product by the user.

### 1.4.2 Handling the Laser Unit

0007-8181

The laser scanner unit emits invisible laser light inside it. If exposed to laser light, the human eye can irreparably be damaged. Never attempt to disassemble the laser scanner unit. (It is not designed for servicing in the field).

The covers around the laser scanner unit are identified by the following label [1].

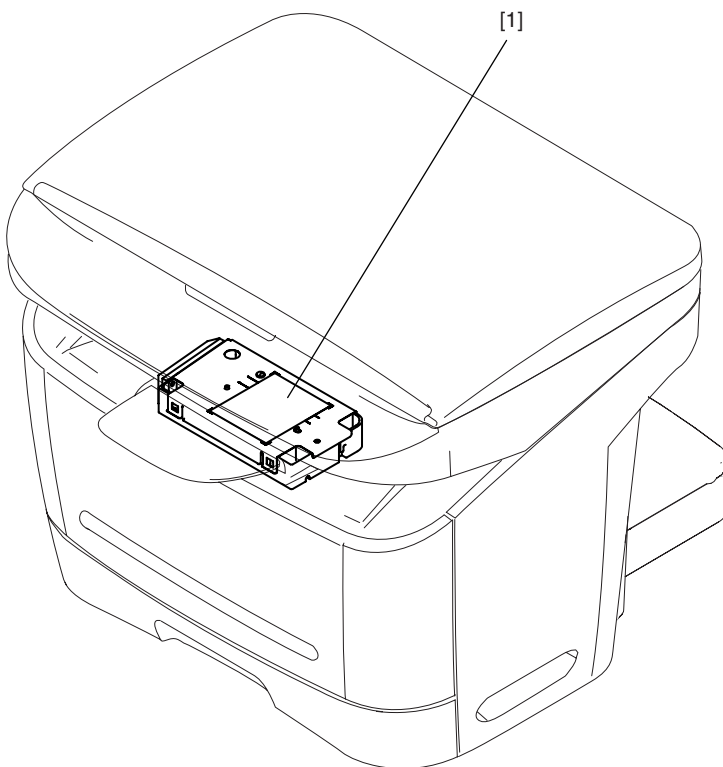

F-1-4

### 1.4.3 Safety of Toner

0002-8619

The machine's toner is a non-toxic material composed of plastic, iron, and small amounts of dye.

---

 Do not put the toner into fire. It may explode.

---

#### Toner on the Skin or Clothes

1. If your skin or clothes came into contact with toner, wash with water at once.
2. Do not use warm or hot water, which will cause the toner to jell, permanently fusing it with the fibers of the clothes.
3. Do not bring toner into contact with vinyl material. They are likely to react with each other.





---

# Chapter 2   TECHNICAL REFERENCE

---



---

---

# Contents

2.1 Document Feed and Exposure System.....	2- 1
2.1.1 Overview/Configuration .....	2- 1
2.1.1.1 Overview .....	2- 1
2.2 Laser Exposure .....	2- 2
2.2.1 Overview/Configuration .....	2- 2
2.2.1.1 Overview .....	2- 2
2.3 Image Formation .....	2- 4
2.3.1 Overview/Configuration .....	2- 4
2.3.1.1 Overview .....	2- 4
2.4 Pickup and Feed System.....	2- 6
2.4.1 Overview/Configuration .....	2- 6
2.4.1.1 Overview .....	2- 6
2.4.2 Detection Jams .....	2- 7
2.4.2.1 Jam Detection Outline .....	2- 7
2.4.2.2 Delay Jams.....	2- 8
2.4.2.3 Stationary Jams.....	2- 8
2.4.2.4 Other Jams .....	2- 8
2.5 Fixing Unit .....	2- 9
2.5.1 Overview/Configuration .....	2- 9
2.5.1.1 Overview .....	2- 9
2.5.2 Protective Function .....	2- 10
2.5.2.1 Protective Mechanisms.....	2- 10
2.5.2.2 Detecting a Fault in the Fixing Assembly .....	2- 11
2.6 External and Controls .....	2- 12
2.6.1 Power Supply .....	2- 12
2.6.1.1 Energy-Saving Function .....	2- 12



---

## 2.1 Document Feed and Exposure System

---

### 2.1.1 Overview/Configuration

#### 2.1.1.1 Overview

0007-8185

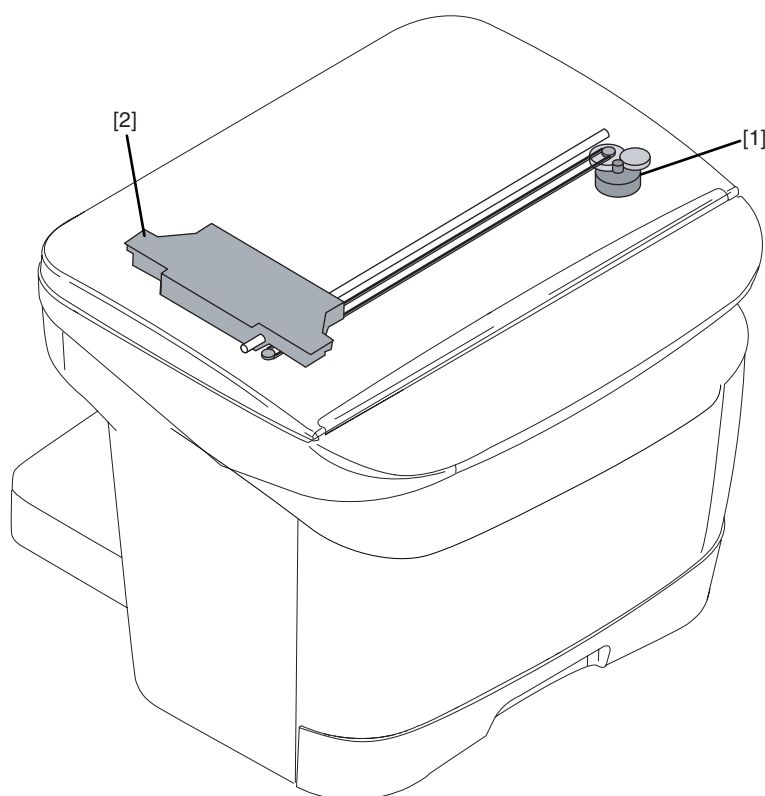

F-2-1

T-2-1

[1] Flatbed motor

[2] CCD unit

The CCD unit driven by the flatbed motor reads out image data of a document on the platen glass.

## 2.2 Laser Exposure

### 2.2.1 Overview/Configuration

#### 2.2.1.1 Overview

0002-8624

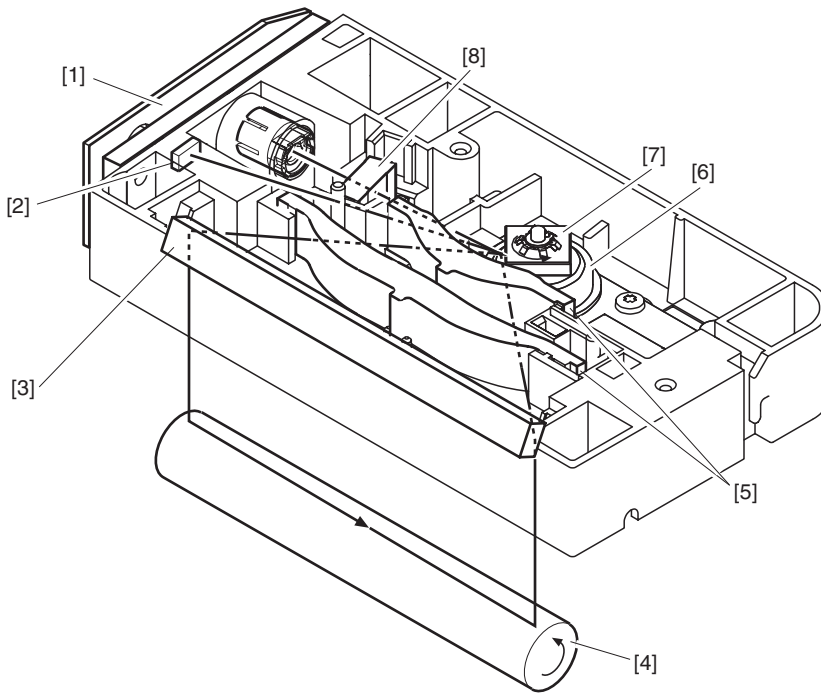

F-2-2

T-2-2

[1] Laser driver PCB

[5] Imaging lenses

[2] BD sensor

[6] Scanner motor

[3] Reflecting mirror

[7] 4-facet mirror

[4] Photosensitive drum

[8] Cylindrical lens

The machine's laser scanner assembly consists of the laser driver and the scanner motor, which are driven by signals coming from the engine controller.

The laser driver serves to turn on the laser diode according to the laser control signal and video signals from the engine controller.

The laser beam moves through the collimator lens and the cylindrical lens to reach the 4-facet mirror rotating at a specific speed.

The laser beam reflected by the 4-facet mirror moves through the imaging lens arranged in front of the 4-facet mirror and the reflecting mirror to reach and focus on the photosensitive drum.

When the 4-facet mirror rotates at a specific speed, the laser beam scans the photosensitive drum in keeping with the mirror rotation, thus drawing static images on the photosensitive drum.

---

Memo:

**BD Fault**

The machine identifies a BD fault if it does not detect the /BDI signal within 0.1 sec after the scanner motor is forced to accelerate. It also detects a BD fault if it does not detect a specific interval of /BDI signals for 2 sec continuously after the scanner motor has reached a specific revolution (number of rotations).

**Scanner Fault**

If the machine does not detect the /BDI signal 1.4 sec after it has stopped forcing the scanner motor to accelerate, it extends the period of detection by 120 sec; if it still does not detect a specific interval of /BDI signals, it identifies a scanner fault.

**BD Error**

The machine identifies a BD error if it does not detect the /BDI signal at a specific interval while the /BDI signal is being generated. It, however, does not identify a BD error under the following condition:

- the door is identified as being open within 0.2 sec after detection of a BD error.
  - a BD fault or a scanner fault is detected after a BD error has been identified.
- 
- 



The laser/scanner unit contains parts that cannot be adjusted in the field. Do not attempt to disassemble the laser/scanner unit.

---

## 2.3 Image Formation

### 2.3.1 Overview/Configuration

#### 2.3.1.1 Overview

0002-8626

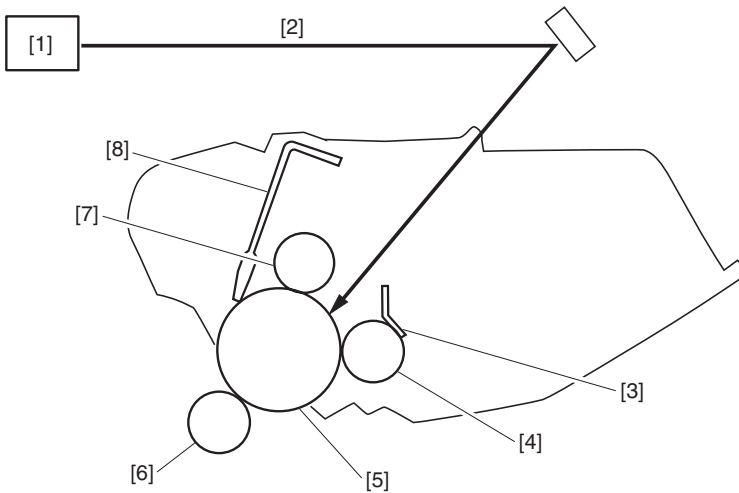

F-2-3

T-2-3

- |                            |                              |
|----------------------------|------------------------------|
| [1] Laser/scanner assembly | [5] Photosensitive drum      |
| [2] Laser beam             | [6] Transfer charging roller |
| [3] Blade                  | [7] Primary charging roller  |
| [4] Developing cylinder    | [8] Cleaning blade           |

In response to a print command, the engine controller turns on the main motor to drive the photosensitive drum, developing cylinder, primary charging roller, and transfer charging roller.

Thereafter, the machine uses the primary charging roller to charge the surface of the photosensitive drum to an even, negative potential and, at the same time, directs the laser beam across the surface of the photosensitive drum. (The laser beam is modulated to according to the incoming video signals.)

The image thus formed on the photosensitive drum is a static, latent image; it is turned into a visible image by means of the toner from the developing cylinder. The resulting toner image is then transferred to paper by the work of the transfer charging roller, and the paper is sent to the fixing assembly. The surface of the photosensitive drum is cleaned by the cleaning blade so that it is free of residual toner; after cleaning, the primary charging roller once again charges the surface to an even, negative potential to prepare for the formation of a new static, latent image.



** Drum Cover Shutter**

If the surface of the photosensitive drum is exposed to strong light, it develops what is known as "photo memory," which can cause white spots or black lines in images. To protect the drum against light, the machine is equipped with a drum cover shutter. The drum cover shutter must never be opened unless doing so proves to be absolutely necessary.

---

## 2.4 Pickup and Feed System

### 2.4.1 Overview/Configuration

#### 2.4.1.1 Overview

0007-9059

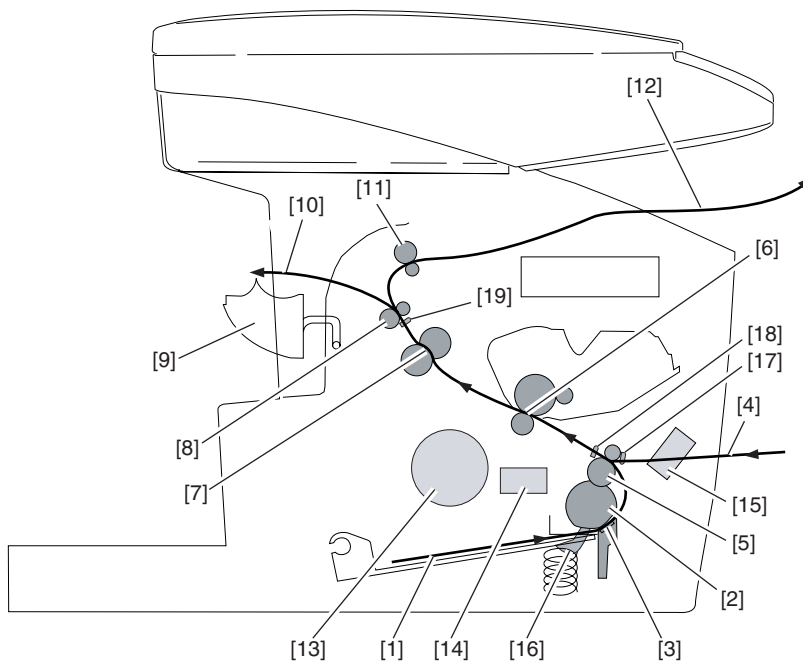

F-2-4

T-2-4

- |   |                                  |
|---|----------------------------------|
| [1] Cassette feed   | [12] Face-down delivery          |
| [2] Cassette pickup roller  | [13] Main motor                  |
| [3] Separation pad  | [14] Cassette pickup solenoid    |
| [4] Manual feed   | [15] Manual feed pickup solenoid |
| [5] Feed roller   | [16] Cassette paper sensor       |
| [6] Transfer assembly (photosensitive drum, transfer charging roller) | [17] Manual feed paper sensor    |
| [7] Fixing assembly (fixing film, fixing pressure roller)             | [18] Top sensor                  |
| [8] Delivery roller   | [19] Delivery sensor             |
| [9] Face-up cover   |                                  |
| [10] Face-up delivery   |                                  |
| [11] Face-down delivery roller  |                                  |

**Pickup and Feed Operation (from the cassette)**

If the cassette paper sensor detects the presence of paper while the absence of paper is identified in the manual feed pickup assembly, the machine picks up paper from the cassette.

When the main motor operates and the cassette pickup solenoid goes on, the cassette pickup roller makes a single rotation to pick up paper. The paper is then moved from the transfer assembly to the fixing assembly by the feed roller; it is ultimately delivered outside the machine by the work of the delivery roller.

When the face-up cover is open, the paper is delivered face-up at the rear of the machine. If the face-up cover is closed, on the other hand, the paper is moved along the feed guide of the cover, and is delivered face-down at the top of the machine by the work of the face-down delivery roller.

**Pickup and Feed Operation (from the manual feed section)**

When paper is inserted into the pickup assembly, the manual feed paper sensor detects the presence of paper, and the machine uses the feed roller to pick and hold the leading edge of the paper. When printing starts, the machine turns on the manual feed pickup solenoid to stop the rotation of the feed roller so that the paper will not move forward until the laser/scanner and the fixing unit become ready for operation. When the laser/scanner and the fixing unit become ready for operation, the machine turns off the manual feed pickup solenoid to rotate the feed roller, thus moving the paper forward; the operation thereafter is identical to the operation used for pickup from the cassette.

## 2.4.2 Detection Jams

### 2.4.2.1 Jam Detection Outline

#### 2.4.2.1.1 Type so Jams

0003-0655

The machine identifies the following types of jams:

**Pickup Delay Jam**

The top sensor does not go on within a specific period of time after pickup starts.

**Pickup Stationary Jam**

The top sensor goes on, but does not go off within a specific period of time.

**Delivery Delay Jam**

The top sensor goes on, but the delivery sensor does not go on within a specific period of time.

**Wrap Jam**

The delivery sensor goes on, but it goes off before a specific period of time passes.

**Delivery Stationary Jam**

The delivery sensor goes on, but it does not go off within a specific period of time.

**Initial Jam**

The top sensor or the delivery sensor goes on while the main motor is starting to rotate.

**Cover Open Jam**

The machine identifies a condition in which the front cover is opened while it is moving paper.

## 2.4.2.2 Delay Jams

### 2.4.2.2.1 Pickup Delay Jam 0003-0657

If the top sensor does not detect the leading edge of paper within 1.2 sec after the start of pickup operation, the machine initiates pickup operation once gain. The machine identifies a pickup delay jam if the top sensor does not detect the leading edge of paper within 1.2 sec after the 2nd pickup operation.

### 2.4.2.2.2 Delivery Delay Jam 0003-0659

The machine identifies a delay jam if the delivery sensor does not detect the leading edge of paper within 1.615 sec after the top sensor has detected the leading edge of paper.

## 2.4.2.3 Stationary Jams

### 2.4.2.3.1 Pickup Stationary Jam 0003-0660

The machine identifies a pickup stationary jam if the top sensor does not detect the absence of paper within 3.575 sec after the top sensor has detected the leading edge of paper.

### 2.4.2.3.2 Delivery Stationary Jam 0003-0662

The machine moves to a delivery stationary jam sequence if it does not detect a wrap jam.  
The machine identifies a delivery stationary jam if the delivery sensor does not detect the trailing edge of paper for 1.715 sec after the top sensor has detected the trailing edge of paper.

## 2.4.2.4 Other Jams

### 2.4.2.4.1 Wrap Jam 0003-0665

The machine starts a wrap jam detection sequence in 0.1 sec if it does not detect a delivery delay jam.  
It identifies a wrap jam if the delivery sensor detects the trailing edge of paper within 1.06 sec after the top sensor has detected the trailing edge of paper.

The term "wrap jam" refers to paper that wraps around the fixing pressure roller; its leading edge passes through the delivery sensor, but it jams thereafter. The machine is designed to identify such a jam so as to prevent wrapping paper from fully moving into the fixing assembly.

### 2.4.2.4.2 Initial Jam 0003-0666

The machine identifies an initial jam if the top sensor or the delivery sensor detects the presence of paper when the main motor starts to rotate.

### 2.4.2.4.3 Cover Open Jam 0003-0663

The machine identifies a cover open jam if it detects that the front cover is open with the top sensor or the delivery sensor detecting the presence of paper (while paper is being moved or the machine is not running a jam check).

## 2.5 Fixing Unit

### 2.5.1 Overview/Configuration

#### 2.5.1.1 Overview

0002-8627

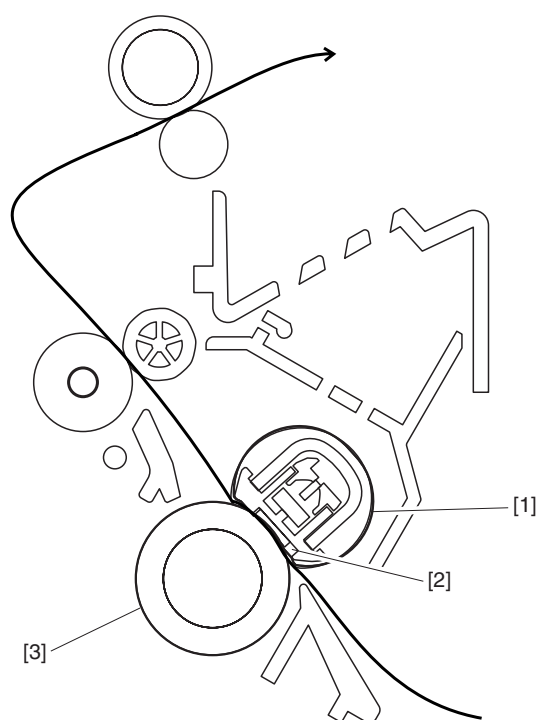

F-2-5

T-2-5

[1] Fixing film unit

[2] Fixing heater

[3] Pressure roller

The machine's fixing system is an on-demand type, and its fixing assembly consists of the fixing film unit and the pressure roller: the fixing film has a built-in fixing heater, thermistor, and thermal fuse.

The toner transferred to paper is heated by the fixing heater, which provides heat through the fixing film; the toner is forced under the pressure roller so that it is fused into the fibers of the paper under both heat and pressure.

## 2.5.2 Protective Function

### 2.5.2.1 Protective Mechanisms

0002-8628

The machine is equipped with the following 3 types of protective mechanisms used to prevent its fixing heater from going awry.

1. protective mechanism by the CPU
2. protective mechanism by the fixing heater safety circuit
3. protective mechanism by the thermal fuse

#### 1. Protective Mechanism by the CPU

The machine's CPU monitors the voltage of the fixing heater temperature detection signal from the main thermistor and the sub thermistor at all times, and it cuts the power to the fixing heater if it finds that the fixing temperature appreciably exceeds a specific level.

When the fixing temperature abnormally increases and the voltage of the fixing heater temperature detection signal from the main thermistor drops to about 0.775 V (equivalent of 235 deg C) or less, the CPU causes the fixing heater drive signal to go Low and turns off the photo triac coupler, thus cutting power to the fixing heater. If the temperature of the fixing heater abnormally increases and the voltage of the fixing heater temperature detection signal from the sub thermistor reaches about 2.779 V (equivalent of 320 deg C) or more, the CPU causes the fixing heater drive signal to go Low and turns off the photo triac couple, thus cutting off the power to the fixing heater.

#### 2. Protective Mechanism by the Fixing Heater Safety Circuit

The fixing heater safety circuit monitors the voltage of the fixing heater temperature detection signal from the main thermistor and the sub thermistor at all times.

If the fixing temperature appreciably exceeds a specific level, the machine cuts off the power to the fixing heater regardless of the instructions from the CPU.

When the temperature of the fixing heater increases abnormally and the voltage of the fixing heater temperature detection signal of the main thermistor reaches about 0.775 V (equivalent of 235 deg C) or less, the output of the comparator turns Low to turn off the relay, thus cutting off the power to the fixing heater.

Likewise, if the temperature of the fixing heater increases abnormally and the voltage of the fixing heater temperature detection signal of the sub thermistor reaches about 2.779 V (equivalent of 320 deg C) or more, the output of the comparator turns Low to turn off the transistor, thus turning off the relay and cutting off the power to the fixing heater regardless of the relay drive signal from the CPU.

#### 3. Protective Mechanism by the Thermal Fuse

If the temperature of the fixing heater increases abnormally and the temperature of the thermal fuse exceeds about 228 deg C, the thermal fuse starts to melt to cut off the power to the fixing heater.

---

---

### 2.5.2.2 Detecting a Fault in the Fixing Assembly

0002-8630

The CPU identifies a fault in the fixing assembly for the following conditions (a. thorough g.) and operates as described:

1. the CPU causes the fixing heater drive signal to go Low to cut off the power to the fixing heater.
2. the CPU causes the relay drive signal to go Low to turn off the relay.
3. the CPU, if it detects a fault while printing is under way, discharges the paper being picked up or moved at the time, and immediately turns off the main motor, scanner motor, and high-voltage system and puts the printer unit in an error state.
- a) the reading of the main thermistor does not exceed 50 deg C within 2.34 sec after the start-up temperature control mechanism is started.
- b) the CPU detects that the reading of the main thermistor remains 235 deg C or more for 1 sec continuously while fixing temperature control is under way.
- c) the CPU detects that the reading of the main thermistor remains 100 deg C or less for 1.2 sec continuously while paper passage temperature control is under way; or the CPU detects that the reading of the main thermistor remains 50 deg C or less for 0.3 sec continuously while between-sheets temperature control is under way.
- d) the CPU detects that the reading of the main thermistor remains less than 20 deg C for 0.3 sec continuously while fixing heater temperature control is under way.
- e) the temperature of the main thermistor does not exceed 100 deg C within 20 sec after the start of start-up temperature control.
- f) the CPU detects that the reading of the sub thermistor remains less than 35 deg C for 0.15 sec continuously while fixing heater temperature control is under way.
- g) the CPU detects that the reading of the sub thermistor remains 320 deg C for 0.15 sec continuously while fixing heater temperature control is under way.

## 2.6 External and Controls

---

### 2.6.1 Power Supply

#### 2.6.1.1 Energy-Saving Function

##### 2.6.1.1.1 Overview

0007-6468

This machine has the Energy Saver mode. When Energy Saver in the User Menu is set to ON, and no operation is made for approx. 5 minutes or more in the stand-by mode, the machine enters the Energy Saver mode. When the Energy Saver key on the control panel is pressed, it also enters the Energy Saver mode.

In the Energy Saver mode, the machine turns off all the LED except Energy Saver key and LCD indications, and the system function will enter the Sleep mode. But the printer section will not enter the Sleep mode.

#### **Recovery from the Energy Saver Mode**

In the Energy Saver mode, the machine always monitors the following activities which are the triggers to resume the operations. When the machine detects any of them, it returns to the stand-by mode.

- The Energy Saver key on the operation panel is pressed
- A print job is accepted
- Paper is set at the Multi-purpose feeder
- The front cover is opened

---

#### **Memo**

In any of the following states, the machine will not enter the Energy Saver mode.

- During the print, scanning operation
  - Out of paper, jam, out of toner, open the front cover, or a service error
  - Energy Saver in the User Menu is turned off
- 

#### **Energy Saver Setting**

To make the Energy Saver mode function, it is necessary to set ENERGY SAVER of TIMER SETTINGS in the User Menu to ON. In this setting, you can set the period of time from the end of the machine operation to entering the Energy Saver mode (3-30 min).



---

# Chapter 3    DISASSEMBLY                   AND ASSEMBLY

---



---

---

# Contents

3.1 EXTERNAL AND CONTROLS SYSTEM .....	3- 1
3.1.1 Front Cover .....	3- 1
3.1.1.1 Removing the Cassette .....	3- 1
3.1.1.2 Removing the front cover .....	3- 1
3.1.2 Rear Cover .....	3- 1
3.1.2.1 Removing the Cassette .....	3- 1
3.1.2.2 Removing the right cover .....	3- 1
3.1.2.3 Removing the left cover .....	3- 2
3.1.2.4 Removing the rear cover .....	3- 2
3.1.3 Top Cover .....	3- 2
3.1.3.1 Removing the Cassette .....	3- 2
3.1.3.2 Removing the right cover .....	3- 2
3.1.3.3 Removing the left cover .....	3- 3
3.1.3.4 Removing the rear cover .....	3- 3
3.1.3.5 Removing the Scanner Unit.....	3- 3
3.1.3.6 Removing the Top Cover .....	3- 4
3.1.4 Right Cover .....	3- 4
3.1.4.1 Removing the Cassette .....	3- 4
3.1.4.2 Removing the right cover .....	3- 4
3.1.5 Left Cover .....	3- 4
3.1.5.1 Removing the Cassette .....	3- 4
3.1.5.2 Removing the left cover .....	3- 5
3.1.6 Operation Panel Unit.....	3- 5
3.1.6.1 Removing the Cassette .....	3- 5
3.1.6.2 Removing the right cover .....	3- 5
3.1.6.3 Removing the left cover .....	3- 6
3.1.6.4 Removing the rear cover .....	3- 6
3.1.6.5 Removing the Scanner Unit.....	3- 6
3.1.6.6 Removing the Board Unit.....	3- 7
3.1.6.7 Removing the Operation Panel Unit.....	3- 7
3.1.7 SCNT Board.....	3- 7
3.1.7.1 Removing the Cassette .....	3- 7
3.1.7.2 Removing the right cover .....	3- 8
3.1.7.3 Removing the left cover .....	3- 8
3.1.7.4 Removing the rear cover .....	3- 8
3.1.7.5 Removing the Scanner Unit.....	3- 9
3.1.7.6 Removing the Board Unit.....	3- 9
3.1.7.7 Removing the SCNT Board.....	3- 10
3.1.8 ECNT Board .....	3- 10
3.1.8.1 Removing the Cassette .....	3- 10
3.1.8.2 Removing the left cover .....	3- 10
3.1.8.3 Removing the ECNT Board .....	3- 10
3.1.9 Power Supply PCB .....	3- 11
3.1.9.1 Removing the Cassette .....	3- 11

3.1.9.2 Removing the right cover .....	3- 11
3.1.9.3 Removing the left cover.....	3- 11
3.1.9.4 Removing the rear cover.....	3- 12
3.1.9.5 Removing the Power Supply Shield Plate .....	3- 12
3.1.9.6 Removing the Power Supply Assembly .....	3- 12
3.1.9.7 Removing the Power Supply Board.....	3- 13
3.1.10 High-voltage Power Supply PCB.....	3- 13
3.1.10.1 Removing the Cassette.....	3- 13
3.1.10.2 Removing the right cover .....	3- 13
3.1.10.3 Removing the left cover.....	3- 14
3.1.10.4 Removing the rear cover.....	3- 14
3.1.10.5 Removing the Power Supply Shield Plate .....	3- 14
3.1.10.6 Removing the Power Supply Assembly .....	3- 15
3.1.10.7 Removing the High-Voltage Power Supply Board.....	3- 15
3.1.11 Top Sensor.....	3- 15
3.1.11.1 Removing the Cassette.....	3- 15
3.1.11.2 Removing the right cover .....	3- 16
3.1.11.3 Removing the left cover.....	3- 16
3.1.11.4 Removing the front cover .....	3- 17
3.1.11.5 Removing the rear cover.....	3- 17
3.1.11.6 Removing the Scanner Unit.....	3- 17
3.1.11.7 Removing the Top Cover.....	3- 18
3.1.11.8 Removing the Right Frame.....	3- 18
3.1.11.9 Removing the Plate.....	3- 18
3.1.11.10 Removing the Left Frame.....	3- 18
3.1.11.11 Removing the Power Supply Shield Plate .....	3- 19
3.1.11.12 Removing the Power Supply Assembly .....	3- 19
3.1.11.13 Removing the Top Sensor.....	3- 19
3.1.12 Paper Delivery Sensor .....	3- 20
3.1.12.1 Removing the Cassette.....	3- 20
3.1.12.2 Removing the right cover .....	3- 20
3.1.12.3 Removing the left cover.....	3- 20
3.1.12.4 Removing the front cover .....	3- 21
3.1.12.5 Removing the rear cover.....	3- 21
3.1.12.6 Removing the Power Supply Shield Plate .....	3- 21
3.1.12.7 Removing the Scanner Unit.....	3- 21
3.1.12.8 Removing the Plate.....	3- 22
3.1.12.9 Removing the Paper Delivery Sensor .....	3- 22
3.2 Document Feed/Exposure System.....	3- 23
3.2.1 Scanner Unit.....	3- 23
3.2.1.1 Removing the Cassette .....	3- 23
3.2.1.2 Removing the right cover .....	3- 23
3.2.1.3 Removing the left cover.....	3- 23
3.2.1.4 Removing the rear cover.....	3- 24
3.2.1.5 Removing the Scanner Unit.....	3- 24
3.2.2 Scanner Cover Unit .....	3- 24
3.2.2.1 Removing the Cassette.....	3- 24
3.2.2.2 Removing the right cover .....	3- 24
3.2.2.3 Removing the left cover.....	3- 25

---

---

3.2.2.4 Removing the rear cover .....	3- 25
3.2.2.5 Removing the Scanner Unit.....	3- 25
3.2.2.6 Removing the Board Unit.....	3- 26
3.2.2.7 Removing the Operation Panel Unit.....	3- 26
3.2.2.8 Removing the Scanner Cover Unit.....	3- 27
3.2.3 CCD Unit .....	3- 27
3.2.3.1 Removing the Cassette .....	3- 27
3.2.3.2 Removing the right cover .....	3- 27
3.2.3.3 Removing the left cover .....	3- 27
3.2.3.4 Removing the rear cover .....	3- 28
3.2.3.5 Removing the Scanner Unit.....	3- 28
3.2.3.6 Removing the Board Unit.....	3- 28
3.2.3.7 Removing the Operation Panel Unit.....	3- 29
3.2.3.8 Removing the Scanner Cover Unit.....	3- 29
3.2.3.9 Removing the Flatbed Motor Unit .....	3- 29
3.2.3.10 Removing the CCD Unit .....	3- 30
3.2.4 Flatbed Motor Unit .....	3- 30
3.2.4.1 Removing the Cassette .....	3- 30
3.2.4.2 Removing the right cover .....	3- 30
3.2.4.3 Removing the left cover .....	3- 31
3.2.4.4 Removing the rear cover .....	3- 31
3.2.4.5 Removing the Scanner Unit.....	3- 31
3.2.4.6 Removing the Board Unit.....	3- 32
3.2.4.7 Removing the Operation Panel Unit.....	3- 32
3.2.4.8 Removing the Scanner Cover Unit.....	3- 32
3.2.4.9 Removing the Flatbed Motor Unit .....	3- 33
3.3 LASER EXPOSURE SYSTEM.....	3- 34
3.3.1 Laser/Scanner Unit.....	3- 34
3.3.1.1 Removing the Cassette .....	3- 34
3.3.1.2 Removing the right cover .....	3- 34
3.3.1.3 Removing the left cover .....	3- 34
3.3.1.4 Removing the rear cover .....	3- 35
3.3.1.5 Removing the Scanner Unit.....	3- 35
3.3.1.6 Removing the Top Cover .....	3- 35
3.3.1.7 Removing the Laser/Scanner Unit.....	3- 36
3.4 IMAGE FORMATION SYSTEM .....	3- 37
3.4.1 Transfer Charging Roller .....	3- 37
3.4.1.1 Removing the Transfer Charging Roller .....	3- 37
3.5 PICKUP AND FEEDING SYSTEM .....	3- 38
3.5.1 Cassette Pickup Roller .....	3- 38
3.5.1.1 Removing the Cassette .....	3- 38
3.5.1.2 Removing the right cover .....	3- 38
3.5.1.3 Removing the left cover .....	3- 38
3.5.1.4 Removing the front cover.....	3- 39
3.5.1.5 Removing the rear cover .....	3- 39
3.5.1.6 Removing the Scanner Unit.....	3- 39
3.5.1.7 Removing the Top Cover .....	3- 40
3.5.1.8 Removing the Right Frame .....	3- 40
3.5.1.9 Removing the Plate.....	3- 40

---



---

3.5.1.10 Removing the Left Frame .....	3- 40
3.5.1.11 Removing the Power Supply Shield Plate .....	3- 41
3.5.1.12 Removing the Power Supply Assembly .....	3- 41
3.5.1.13 Removing the Gear Unit.....	3- 41
3.5.1.14 Removing the Tooth-Missing Gear .....	3- 42
3.5.1.15 Removing the Cassette Pickup Roller .....	3- 42
3.5.2 Cassette Pickup Solenoid .....	3- 42
3.5.2.1 Removing the Cassette.....	3- 42
3.5.2.2 Removing the right cover .....	3- 42
3.5.2.3 Removing the left cover.....	3- 43
3.5.2.4 Removing the front cover .....	3- 43
3.5.2.5 Removing the rear cover.....	3- 43
3.5.2.6 Removing the Scanner Unit.....	3- 44
3.5.2.7 Removing the Top Cover.....	3- 44
3.5.2.8 Removing the Right Frame.....	3- 44
3.5.2.9 Removing the Plate .....	3- 45
3.5.2.10 Removing the Left Frame .....	3- 45
3.5.2.11 Removing the Power Supply Shield Plate .....	3- 45
3.5.2.12 Removing the Power Supply Assembly .....	3- 45
3.5.2.13 Removing the Cassette Pickup Solenoid .....	3- 46
3.5.3 Cassette Separation Pad .....	3- 46
3.5.3.1 Removing the Rear of the Cassette.....	3- 46
3.5.3.2 Removing the Cassette Separation Pad .....	3- 46
3.5.4 Paper Feed Roller .....	3- 47
3.5.4.1 Removing the Cassette.....	3- 47
3.5.4.2 Removing the right cover .....	3- 47
3.5.4.3 Removing the left cover.....	3- 47
3.5.4.4 Removing the front cover .....	3- 48
3.5.4.5 Removing the rear cover.....	3- 48
3.5.4.6 Removing the Scanner Unit.....	3- 48
3.5.4.7 Removing the Top Cover.....	3- 49
3.5.4.8 Removing the Right Frame.....	3- 49
3.5.4.9 Removing the Plate .....	3- 49
3.5.4.10 Removing the Left Frame .....	3- 49
3.5.4.11 Removing the Power Supply Shield Plate .....	3- 50
3.5.4.12 Removing the Power Supply Assembly .....	3- 50
3.5.4.13 Removing the Gear Unit.....	3- 50
3.5.4.14 Removing the Tooth-Missing Gear .....	3- 51
3.5.4.15 Removing the Manual Stay.....	3- 51
3.5.4.16 Removing the Paper Feed Guide .....	3- 51
3.5.4.17 Removing the Paper Feed Roller .....	3- 52
3.5.5 Manual Pickup Solenoid .....	3- 52
3.5.5.1 Removing the Cassette.....	3- 52
3.5.5.2 Removing the right cover .....	3- 52
3.5.5.3 Removing the left cover.....	3- 52
3.5.5.4 Removing the front cover .....	3- 53
3.5.5.5 Removing the rear cover.....	3- 53
3.5.5.6 Removing the Scanner Unit.....	3- 53
3.5.5.7 Removing the Top Cover.....	3- 54

---



---

3.5.5.8 Removing the Right Frame .....	3- 54
3.5.5.9 Removing the Plate.....	3- 54
3.5.5.10 Removing the Left Frame.....	3- 54
3.5.5.11 Removing the Power Supply Shield Plate.....	3- 55
3.5.5.12 Removing the Power Supply Assembly .....	3- 55
3.5.5.13 Removing the Manual Pickup Solenoid.....	3- 55
3.5.6 Main Motor .....	3- 56
3.5.6.1 Removing the Cassette .....	3- 56
3.5.6.2 Removing the right cover .....	3- 56
3.5.6.3 Removing the left cover .....	3- 56
3.5.6.4 Removing the front cover.....	3- 57
3.5.6.5 Removing the rear cover .....	3- 57
3.5.6.6 Removing the Scanner Unit.....	3- 57
3.5.6.7 Removing the Top Cover .....	3- 58
3.5.6.8 Removing the Right Frame .....	3- 58
3.5.6.9 Removing the Plate.....	3- 58
3.5.6.10 Removing the Left Frame.....	3- 58
3.5.6.11 Removing the Power Supply Shield Plate.....	3- 59
3.5.6.12 Removing the Power Supply Assembly .....	3- 59
3.5.6.13 Removing the Main Motor .....	3- 59
3.5.7 Gear Unit.....	3- 60
3.5.7.1 Removing the Cassette .....	3- 60
3.5.7.2 Removing the right cover .....	3- 60
3.5.7.3 Removing the Gear Unit.....	3- 60
3.6 FIXING SYSTEM.....	3- 61
3.6.1 Fixing Film Unit .....	3- 61
3.6.1.1 Removing the Cassette .....	3- 61
3.6.1.2 Removing the right cover .....	3- 61
3.6.1.3 Removing the left cover .....	3- 61
3.6.1.4 Removing the front cover.....	3- 62
3.6.1.5 Removing the rear cover .....	3- 62
3.6.1.6 Removing the Scanner Unit.....	3- 62
3.6.1.7 Removing the Top Cover .....	3- 63
3.6.1.8 Removing the Right Frame .....	3- 63
3.6.1.9 Removing the Plate.....	3- 63
3.6.1.10 Removing the Left Frame.....	3- 63
3.6.1.11 Removing the Power Supply Shield Plate.....	3- 64
3.6.1.12 Removing the Fixing Film Unit .....	3- 64
3.6.2 Fixing Pressure Roller.....	3- 65
3.6.2.1 Removing the Cassette .....	3- 65
3.6.2.2 Removing the right cover .....	3- 65
3.6.2.3 Removing the left cover .....	3- 65
3.6.2.4 Removing the front cover.....	3- 66
3.6.2.5 Removing the rear cover .....	3- 66
3.6.2.6 Removing the Scanner Unit.....	3- 66
3.6.2.7 Removing the Top Cover .....	3- 67
3.6.2.8 Removing the Right Frame .....	3- 67
3.6.2.9 Removing the Plate.....	3- 67
3.6.2.10 Removing the Left Frame.....	3- 67

3.6.2.11 Removing the Power Supply Shield Plate .....	3- 68
3.6.2.12 Removing the Fixing Film Unit.....	3- 68
3.6.2.13 Removing the Fixing Pressure Roller .....	3- 69



## 3.1 EXTERNAL AND CONTROLS SYSTEM

### 3.1.1 Front Cover

#### 3.1.1.1 Removing the Cassette 0002-6889

- 1) Remove the cassette by holding the cassette handle.

#### 3.1.1.2 Removing the front cover 0007-7439

- 1) Open the front cover [1] and remove the arm claws [2] to disengage the connection.
- 2) Remove the shafts on both sides [3] while warping the shaft arms inside, and remove the front cover.

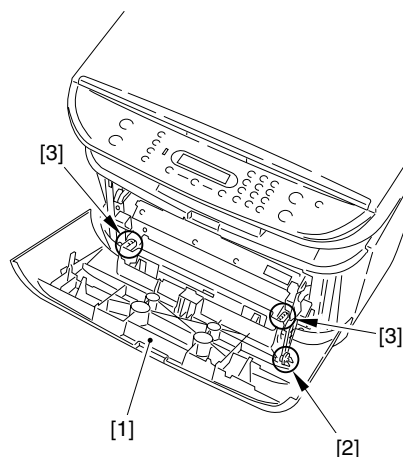

F-3-1

### 3.1.2 Rear Cover

#### 3.1.2.1 Removing the Cassette 0002-6890

- 1) Remove the cassette by holding the cassette handle.

#### 3.1.2.2 Removing the right cover 0007-7442

- 1) Open the front cover [1], and remove the 2 screws [2] on the front side.

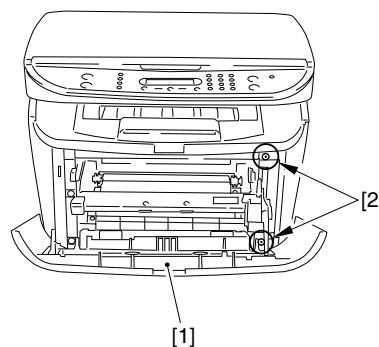

F-3-2

- 2) Remove the 2 screws [1] on the back side, and remove the right cover [2].

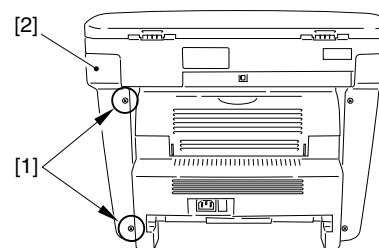

F-3-3

### 3.1.2.3 Removing the left cover 0007-7446

- 1) Open the front cover [1], and remove the 2 screws [2] on the front side.

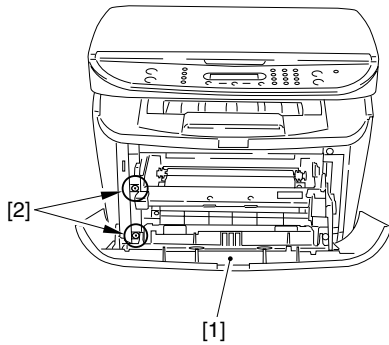

F-3-4

- 2) Remove the 2 screws [1] on the back side, and remove the left cover [2].

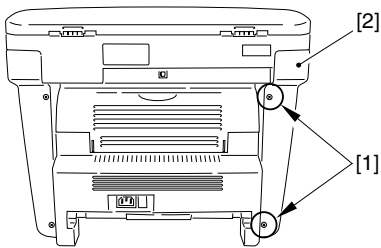

F-3-5

### 3.1.2.4 Removing the rear cover 0007-7449

- 1) Opening the face-up cover [1], and then lower the fixing pressure release levers [2] on both sides and release the pressure.
- 2) Remove 2 screws [3].
- 3) Remove the rear cover [4] as you pull it toward you.

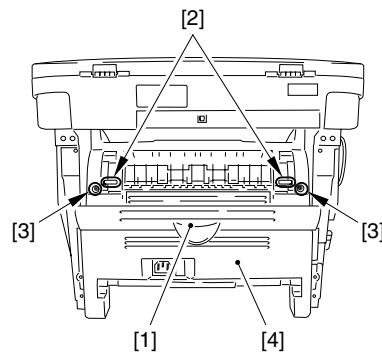

F-3-6

## 3.1.3 Top Cover

### 3.1.3.1 Removing the Cassette 0002-6891

- 1) Remove the cassette by holding the cassette handle.

### 3.1.3.2 Removing the right cover 0007-7443

- 1) Open the front cover [1], and remove the 2 screws [2] on the front side.

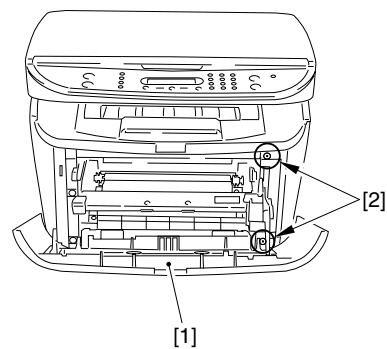

F-3-7

- 2) Remove the 2 screws [1] on the back side, and remove the right cover [2].

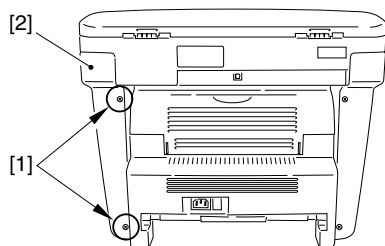

F-3-8

### 3.1.3.3 Removing the left cover 0007-7447

- 1) Open the front cover [1], and remove the 2 screws [2] on the front side.

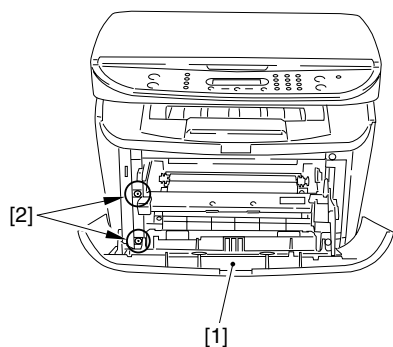

F-3-9

- 2) Remove the 2 screws [1] on the back side, and remove the left cover [2].

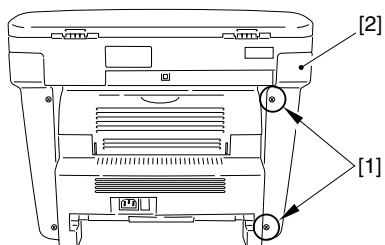

F-3-10

### 3.1.3.4 Removing the rear cover 0007-7450

- 1) Opening the face-up cover [1], and then lower the

fixing pressure release levers [2] on both sides and release the pressure.

- 2) Remove 2 screws [3].

- 3) Remove the rear cover [4] as you pull it toward you.

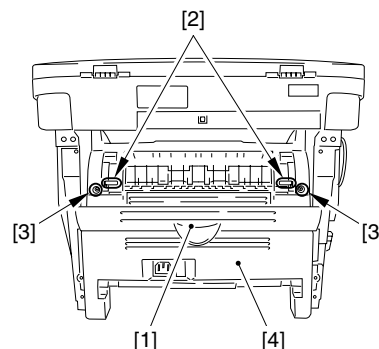

F-3-11

### 3.1.3.5 Removing the Scanner

Unit

0007-7460

- 1) Remove the connector [1] and the flat cable [2] on the ECNT board, and remove the screw [3]. (Remove the flat cable from the core.)
- 2) Remove the 2 screws [4] and the 2 pins [5] on the right and left sides.

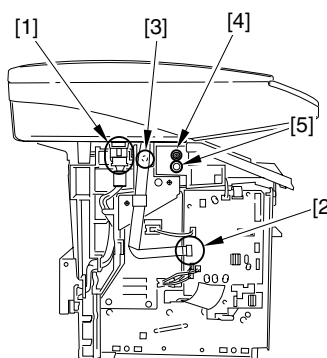

F-3-12

- 3) Remove the 2 screws on the back [1]. Slide the scanner unit [2] to the back; then, remove it by lifting it.

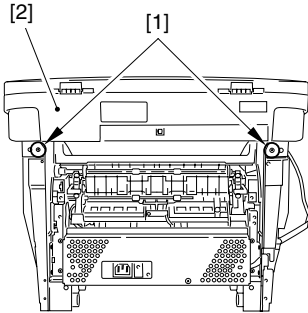

F-3-13

### 3.1.3.6 Removing the Top Cover 0007-7461

- 1) Remove the 2 screws [1], and remove the Top cover [2].

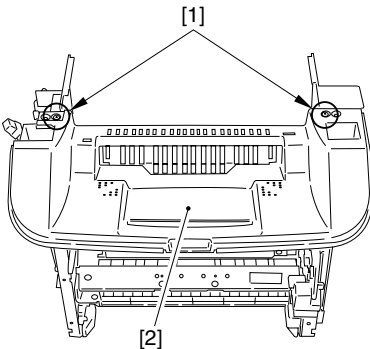

F-3-14

## 3.1.4 Right Cover

### 3.1.4.1 Removing the Cassette 0002-6871

- 1) Remove the cassette by holding the cassette handle.

### 3.1.4.2 Removing the right cover 0007-7418

- 1) Open the front cover [1], and remove the 2 screws [2] on the front side.

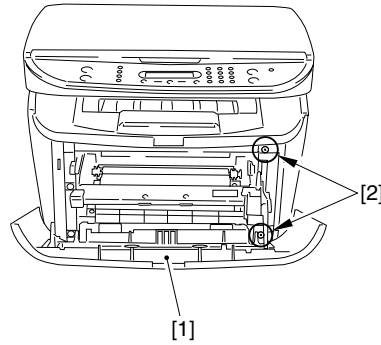

F-3-15

- 2) Remove the 2 screws [1] on the back side, and remove the right cover [2].

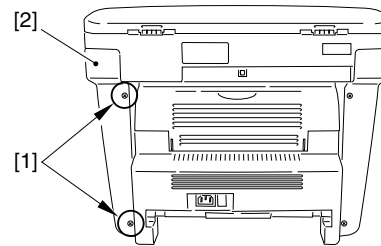

F-3-16

## 3.1.5 Left Cover

### 3.1.5.1 Removing the Cassette 0002-6874

- 1) Remove the cassette by holding the cassette handle.

### 3.1.5.2 Removing the left cover [0007-7419](#)

- 1) Open the front cover [1], and remove the 2 screws [2] on the front side.

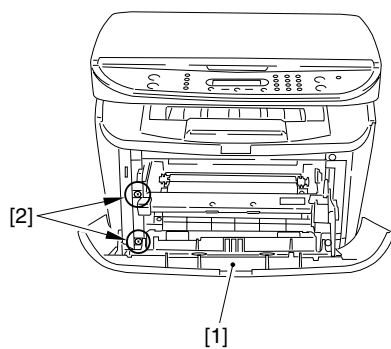

F-3-17

- 2) Remove the 2 screws [1] on the back side, and remove the left cover [2].

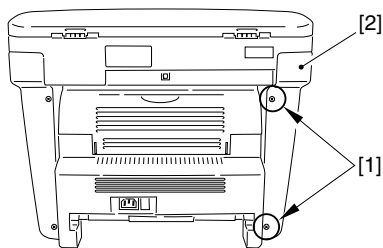

F-3-18

### 3.1.6 Operation Panel Unit

#### 3.1.6.1 Removing the Cassette [0007-9904](#)

#### 3.1.6.2 Removing the right cover [0007-7486](#)

- 1) Open the front cover [1], and remove the 2 screws [2] on the front side.

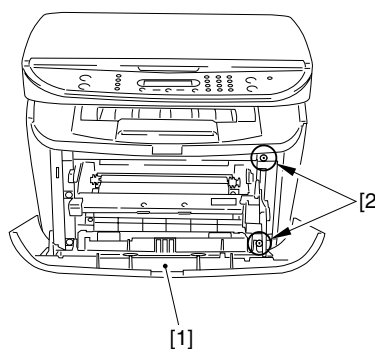

F-3-19

- 2) Remove the 2 screws [1] on the back side, and remove the right cover [2].

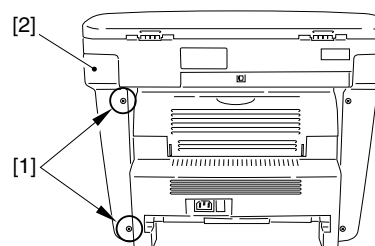

F-3-20

### 3.1.6.3 Removing the left cover 0007-7487

- 1) Open the front cover [1], and remove the 2 screws [2] on the front side.

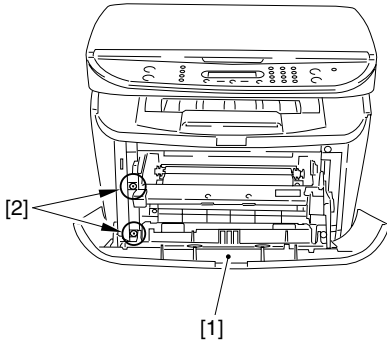

F-3-21

- 2) Remove the 2 screws [1] on the back side, and remove the left cover [2].

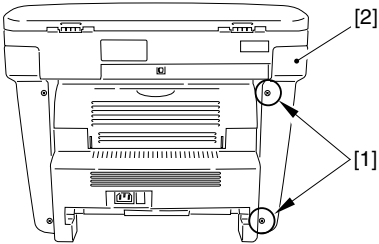

F-3-22

### 3.1.6.4 Removing the rear cover 0007-7488

- 1) Opening the face-up cover [1], and then lower the fixing pressure release levers [2] on both sides and release the pressure.
- 2) Remove 2 screws [3].
- 3) Remove the rear cover [4] as you pull it toward you.

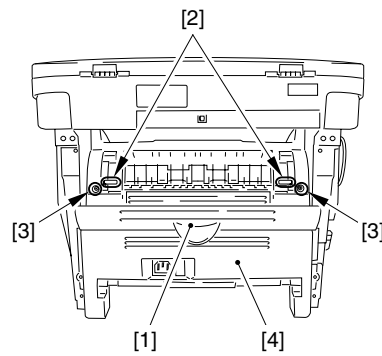

F-3-23

### 3.1.6.5 Removing the Scanner Unit 0007-7489

- 1) Remove the connector [1] and the flat cable [2] on the ECNT board, and remove the screw [3]. (Remove the flat cable from the core.)
- 2) Remove the 2 screws [4] and the 2 pins [5] on the right and left sides.

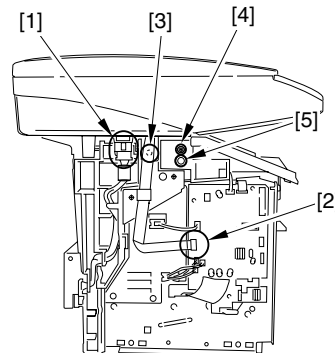

F-3-24

- 3) Remove the 2 screws on the back [1]. Slide the scanner unit [2] to the back; then, remove it by lifting it.

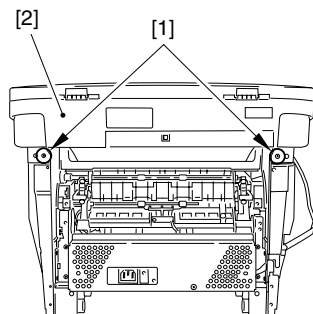

F-3-25

### 3.1.6.6 Removing the Board Unit

0007-7490

- 1) Remove the 4 screws [1] on the back side of the scanner unit.

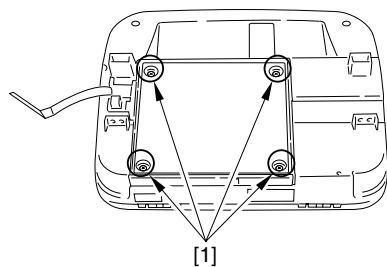

F-3-26

- 2) Open the board unit [1], and remove the connector [2], the grounding cable [3] and the 3 flat cables [4].

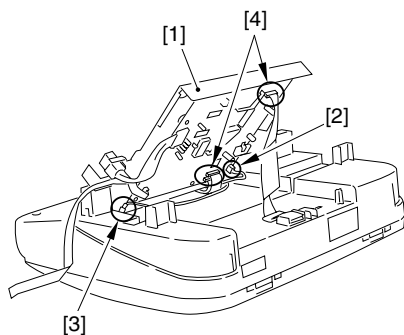

F-3-27

### 3.1.6.7 Removing the Operation Panel Unit

0007-7491

- 1) Remove the 2 screws [1], and remove the flat cable from the core.

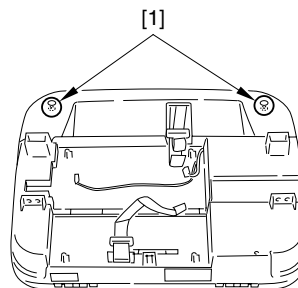

F-3-28

- 2) Remove the 2 claws [2] on the operation panel unit [1], and remove the operation panel unit.

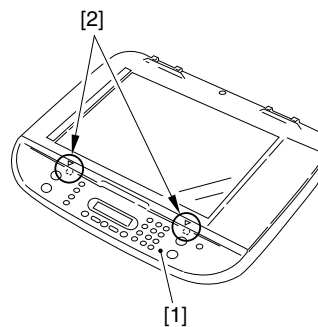

F-3-29

## 3.1.7 SCNT Board

### 3.1.7.1 Removing the Cassette

0006-2984

- 1) Remove the cassette by holding the cassette handle.

### 3.1.7.2 Removing the right cover

0007-7476

- 1) Open the front cover [1], and remove the 2 screws [2] on the front side.

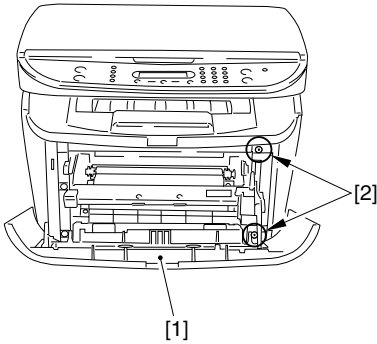

F-3-30

- 2) Remove the 2 screws [1] on the back side, and remove the right cover [2].

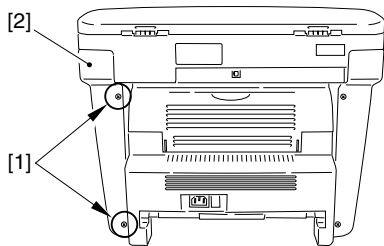

F-3-31

### 3.1.7.3 Removing the left cover 0007-7477

- 1) Open the front cover [1], and remove the 2 screws [2] on the front side.

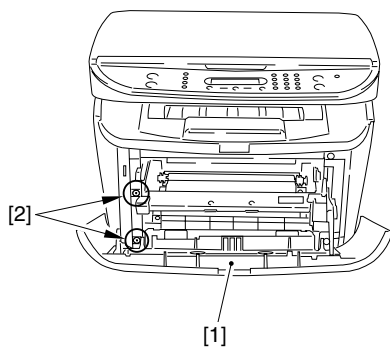

F-3-32

- 2) Remove the 2 screws [1] on the back side, and remove the left cover [2].

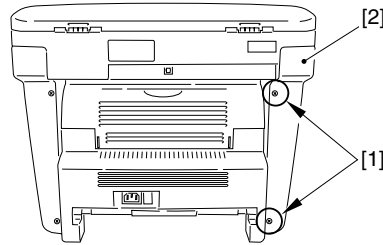

F-3-33

### 3.1.7.4 Removing the rear cover

0007-7478

- 1) Opening the face-up cover [1], and then lower the fixing pressure release levers [2] on both sides and release the pressure.
- 2) Remove 2 screws [3].
- 3) Remove the rear cover [4] as you pull it toward you.

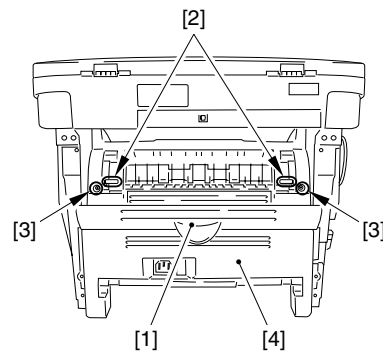

F-3-34



### 3.1.7.5 Removing the Scanner

Unit 0007-7479

- 1) Remove the connector [1] and the flat cable [2] on the ECNT board, and remove the screw [3]. (Remove the flat cable from the core.)
- 2) Remove the 2 screws [4] and the 2 pins [5] on the right and left sides.

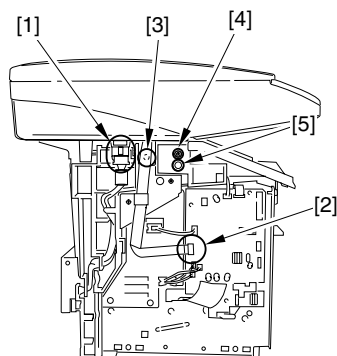

F-3-35

- 3) Remove the 2 screws on the back [1]. Slide the scanner unit [2] to the back; then, remove it by lifting it.

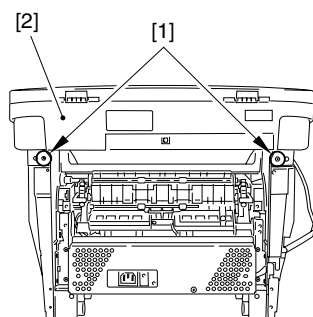

F-3-36

### 3.1.7.6 Removing the Board

Unit 0007-7480

- 1) Remove the 4 screws [1] on the back side of the scanner unit.

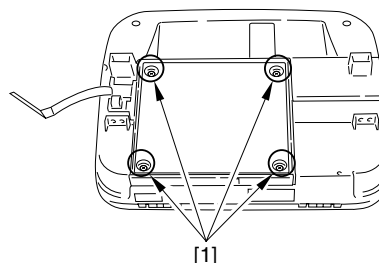

F-3-37

- 2) Open the board unit [1], and remove the connector [2], the grounding cable [3] and the 3 flat cables [4].

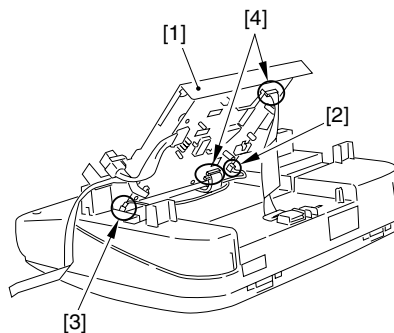

F-3-38

### 3.1.7.7 Removing the SCNT

Board

0007-7483

- 1) Remove the connector [1] and the flat cable [2].
- 2) Remove the 7 screws [3] and remove the SCNT board [4].

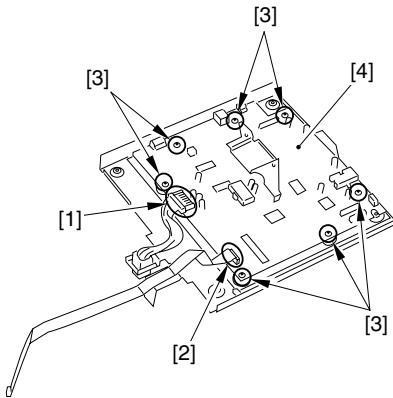

F-3-39

- 2) Remove the 2 screws [1] on the back side, and remove the left cover [2].

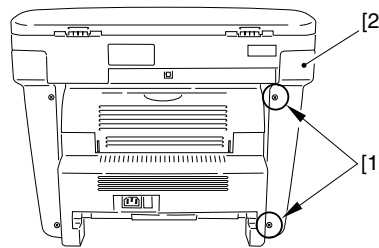

F-3-41

### 3.1.8.3 Removing the ECNT

Board

0007-9239

- 1) Take off the connectors at 5 spots [1] as well as the flat cable at 3 spots [2].
- 2) Remove the 3 screws [3] and, while carefully watching the sensor flag, removes the ECNT board [4].

## 3.1.8 ECNT Board

### 3.1.8.1 Removing the Cassette

0007-9905

### 3.1.8.2 Removing the left cover

0007-9240

- 1) Open the front cover [1], and remove the 2 screws [2] on the front side.

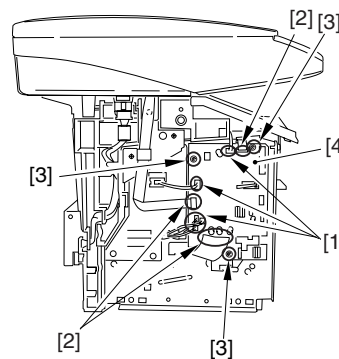

F-3-42

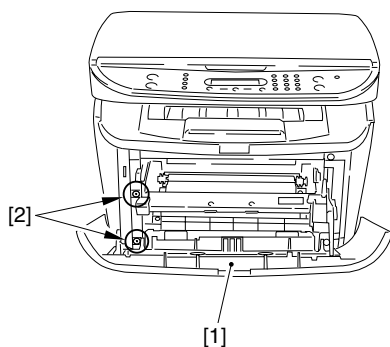

F-3-40

### 3.1.9 Power Supply PCB

#### 3.1.9.1 Removing the Cassette [0002-7493](#)

- 1) Remove the cassette by holding the cassette handle.

#### 3.1.9.2 Removing the right cover [0007-7564](#)

- 1) Open the front cover [1], and remove the 2 screws [2] on the front side.

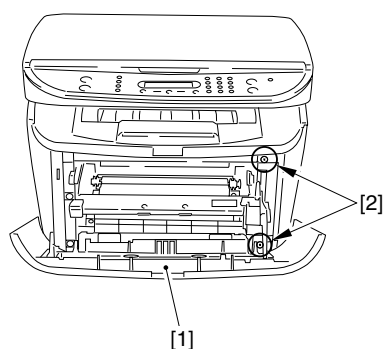

F-3-43

- 2) Remove the 2 screws [1] on the back side, and remove the right cover [2].

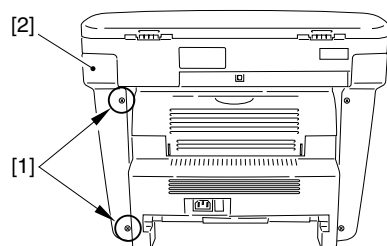

F-3-44

#### 3.1.9.3 Removing the left cover [0007-7568](#)

- 1) Open the front cover [1], and remove the 2 screws [2] on the front side.

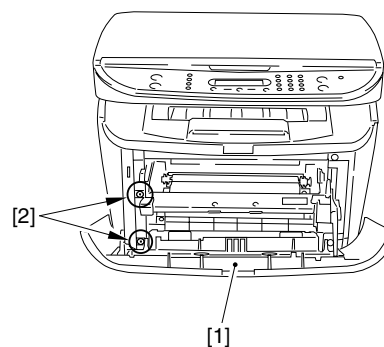

F-3-45

- 2) Remove the 2 screws [1] on the back side, and remove the left cover [2].

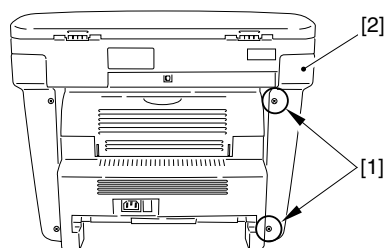

F-3-46

### 3.1.9.4 Removing the rear cover

0007-7570

- 1) Opening the face-up cover [1], and then lower the fixing pressure release levers [2] on both sides and release the pressure.
- 2) Remove 2 screws [3].
- 3) Remove the rear cover [4] as you pull it toward you.

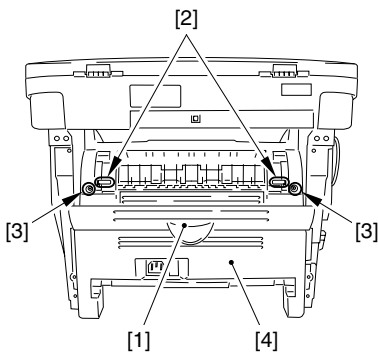

F-3-47

### 3.1.9.5 Removing the Power Supply Shield Plate

0007-7694

- 1) Remove the connector [1] and remove the cable from the cable guide.

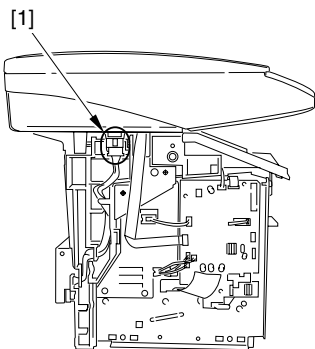

F-3-48

- 2) Remove the 9 screws [1] to remove the power supply shield plate [2].

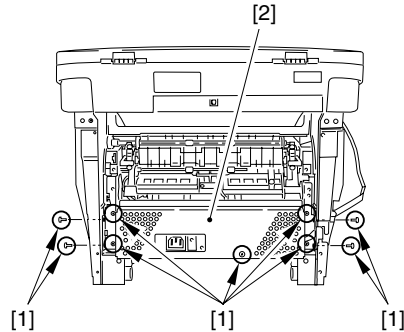

F-3-49

### 3.1.9.6 Removing the Power Supply Assembly

0007-7697

- 1) Remove the 3 screws [1]. (The external cover is omitted from the illustration below to show the instructions clearly.)
- 2) Remove the four connectors [2] as well as the flat cable [3] on the ECNT board.

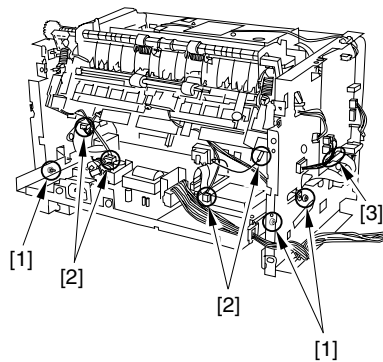

F-3-50

- 3) As you remove the bosses on both sides [1], lower the front part of the power supply assembly [2]. Then pull it to remove the power supply assembly.

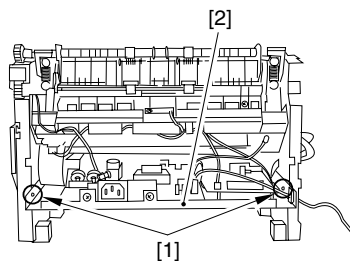

F-3-51

### 3.1.9.7 Removing the Power Supply Board 0007-7698

- 1) Remove the connector [1] and the flat cable [2].
- 2) Remove the 4 screws [3]. As you disengage the 3 spacers [4], remove the power supply board [5].

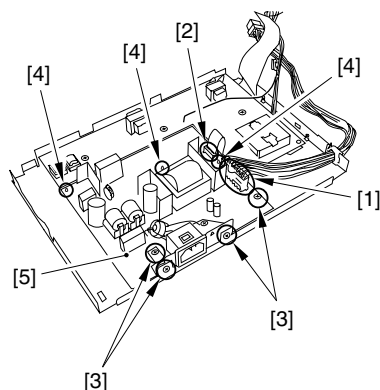

F-3-52

## 3.1.10 High-voltage Power Supply PCB

### 3.1.10.1 Removing the Cassette 0002-7494

- 1) Remove the cassette by holding the cassette handle.

### 3.1.10.2 Removing the right cover 0007-7702

- 1) Open the front cover [1], and remove the 2 screws [2] on the front side.

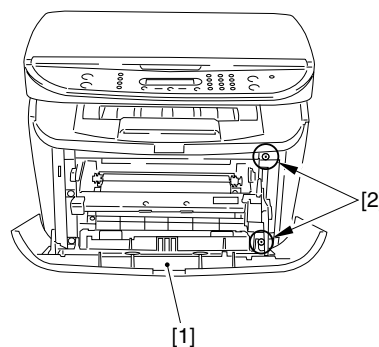

F-3-53

- 2) Remove the 2 screws [1] on the back side, and remove the right cover [2].

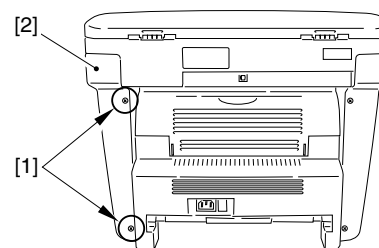

F-3-54

### 3.1.10.3 Removing the left cover

0007-7703

- 1) Open the front cover [1], and remove the 2 screws [2] on the front side.

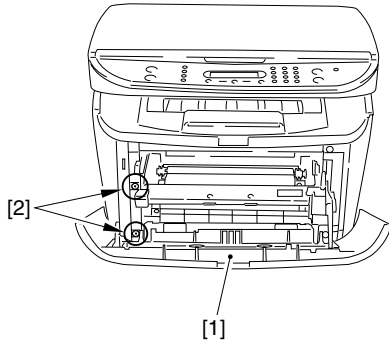

F-3-55

- 2) Remove the 2 screws [1] on the back side, and remove the left cover [2].

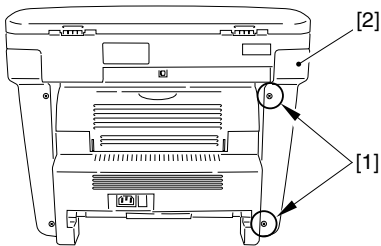

F-3-56

### 3.1.10.4 Removing the rear cover

0007-7704

- 1) Opening the face-up cover [1], and then lower the fixing pressure release levers [2] on both sides and release the pressure.
- 2) Remove 2 screws [3].
- 3) Remove the rear cover [4] as you pull it toward you.

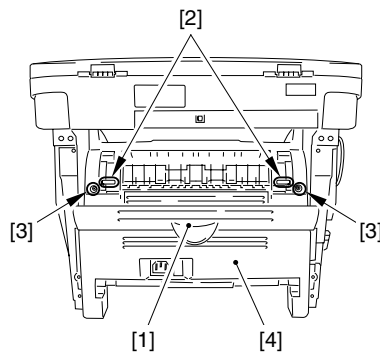

F-3-57

### 3.1.10.5 Removing the Power Supply Shield Plate

0007-7706

- 1) Remove the connector [1] and remove the cable from the cable guide.

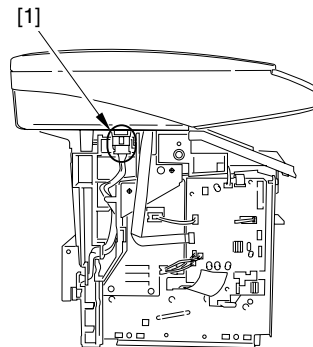

F-3-58

- 2) Remove the 9 screws [1] to remove the power supply shield plate [2].

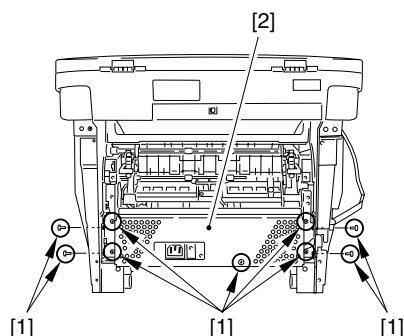

F-3-59

### 3.1.10.6 Removing the Power Supply Assembly [0007-7707](#)

- 1) Remove the 3 screws [1]. (The external cover is omitted from the illustration below to show the instructions clearly.)
- 2) Remove the four connectors [2] as well as the flat cable [3] on the ECNT board.

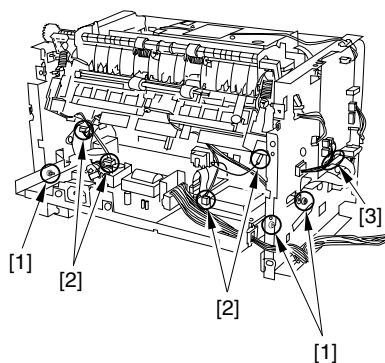

F-3-60

- 3) As you remove the bosses on both sides [1], lower the front part of the power supply assembly [2]. Then pull it to remove the power supply assembly.

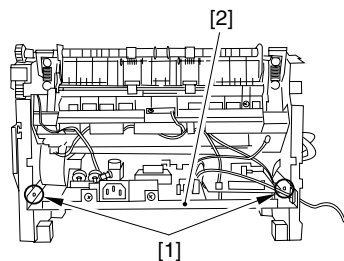

F-3-61

### 3.1.10.7 Removing the High-Voltage Power Supply Board [0007-7709](#)

- 1) Remove the flat cable [1].
- 2) Remove the 3 screws [2] and the high-voltage power supply board [3].

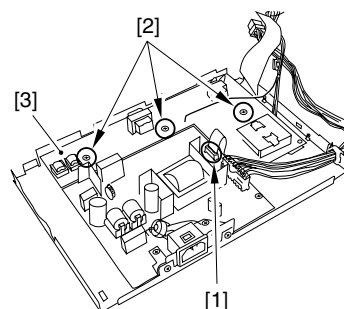

F-3-62

### 3.1.11 Top Sensor

#### 3.1.11.1 Removing the Cassette [0002-7635](#)

- 1) Remove the cassette by holding the cassette handle.

### 3.1.11.2 Removing the right cover

0007-7533

- 1) Open the front cover [1], and remove the 2 screws [2] on the front side.

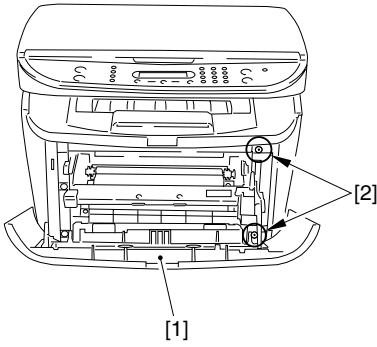

F-3-63

- 2) Remove the 2 screws [1] on the back side, and remove the right cover [2].

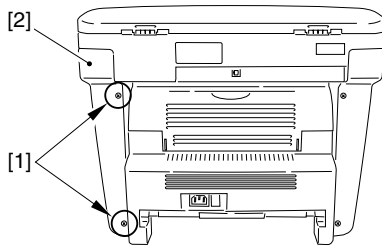

F-3-64

### 3.1.11.3 Removing the left cover

0007-7534

- 1) Open the front cover [1], and remove the 2 screws [2] on the front side.

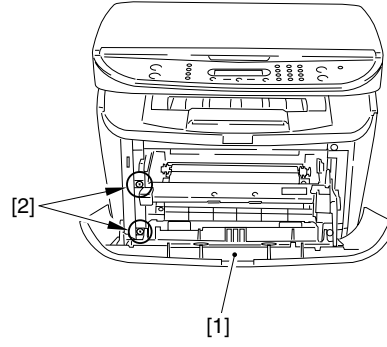

F-3-65

- 2) Remove the 2 screws [1] on the back side, and remove the left cover [2].

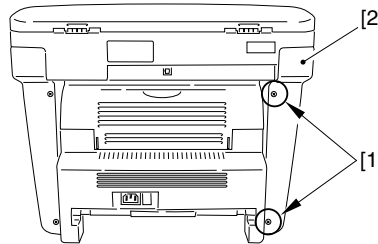

F-3-66



### 3.1.11.4 Removing the front cover

0007-7536

- 1) Open the front cover [1] and remove the arm claws [2] to disengage the connection.
- 2) Remove the shafts on both sides [3] while warping the shaft arms inside, and remove the front cover.

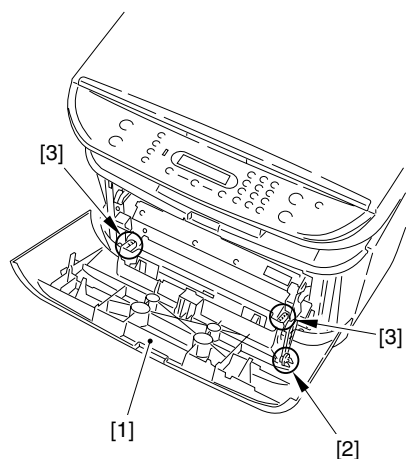

F-3-67

### 3.1.11.5 Removing the rear cover

0007-7537

- 1) Opening the face-up cover [1], and then lower the fixing pressure release levers [2] on both sides and release the pressure.
- 2) Remove 2 screws [3].
- 3) Remove the rear cover [4] as you pull it toward you.

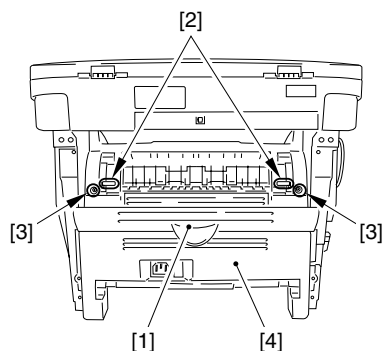

F-3-68

### 3.1.11.6 Removing the Scanner Unit

0007-7538

- 1) Remove the connector [1] and the flat cable [2] on the ECNT board, and remove the screw [3]. (Remove the flat cable from the core.)
- 2) Remove the 2 screws [4] and the 2 pins [5] on the right and left sides.

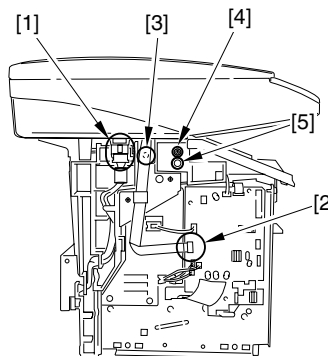

F-3-69

- 3) Remove the 2 screws on the back [1]. Slide the scanner unit [2] to the back; then, remove it by lifting it.

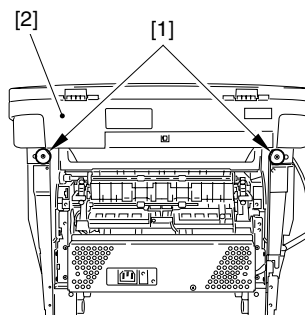

F-3-70

### 3.1.11.7 Removing the Top Cover

0007-7539

- 1) Remove the 2 screws [1], and remove the Top cover [2].

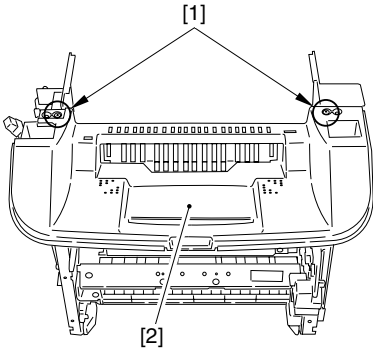

F-3-71

### 3.1.11.8 Removing the Right Frame

0007-7542

- 1) Remove the 3 screws [1], and remove the right frame [2].

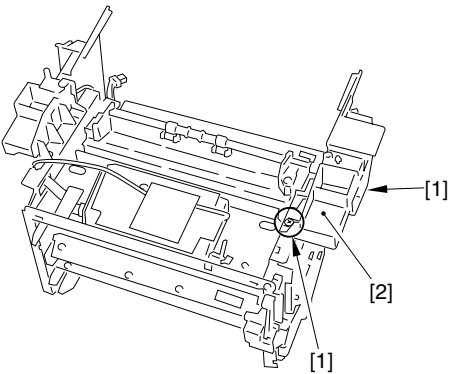

F-3-72

### 3.1.11.9 Removing the Plate

0007-7544

- 1) Remove the connector [1] of the ECNT board.
- 2) Remove the 3 screws [2] and then removes the plate [3].

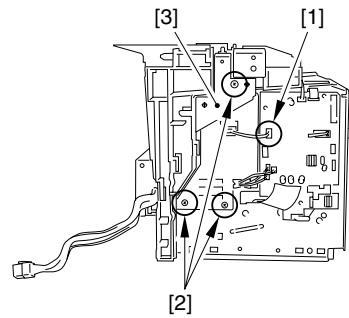

F-3-73

### 3.1.11.10 Removing the Left Frame

0007-7545

- 1) Remove the cable [1] from the cable guide.
- 2) Remove the 2 screws [2], and remove the left frame [3].

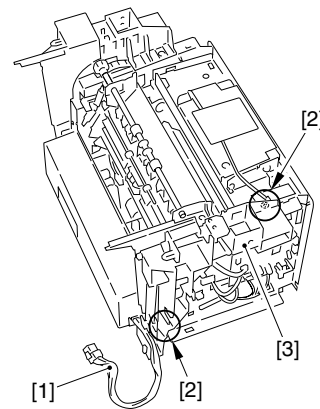

F-3-74

### 3.1.11.11 Removing the Power

#### Supply Shield Plate

0007-7547

- 1) Remove the 5 screws [1] to remove the power supply shield plate [2].

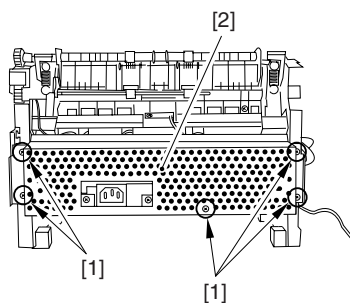

F-3-75

### 3.1.11.12 Removing the Power

#### Supply Assembly

0007-7550

- 1) Remove the 3 screws [1].
- 2) Remove the 4 connectors [2] as well as the flat cable [3] on the ECNT board.

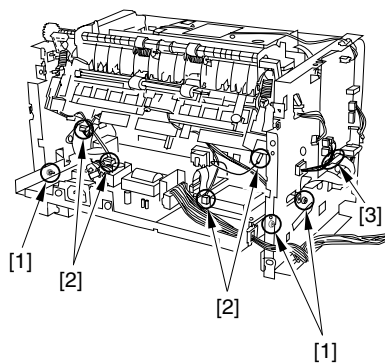

F-3-76

- 3) As you remove the bosses on both sides [1], lower the front part of the power supply assembly [2]. Then pull it to remove the power supply assembly.

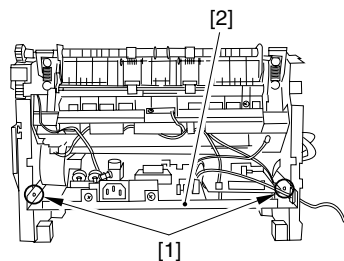

F-3-77

### 3.1.11.13 Removing the Top

#### Sensor

0007-7552

- 1) Place the main unit down on its front face (so that the interior of the main unit is easily visible).
- 2) Remove the connector [1] on the ECNT board and take the cable off the cable guide.
- 3) Remove the screw [2] and remove the top sensor [3].

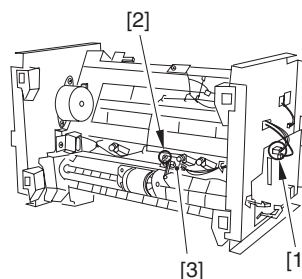

F-3-78

### 3.1.12 Paper Delivery Sensor

#### 3.1.12.1 Removing the Cassette [0002-7634](#)

- 1) Remove the cassette by holding the cassette handle.

#### 3.1.12.2 Removing the right cover [0007-7553](#)

- 1) Open the front cover [1], and remove the 2 screws [2] on the front side.

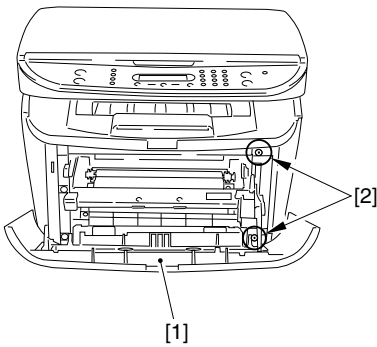

F-3-79

- 2) Remove the 2 screws [1] on the back side, and remove the right cover [2].

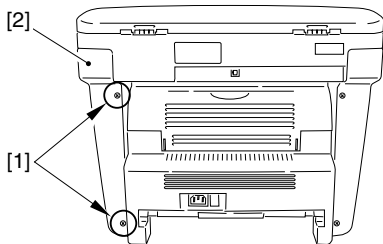

F-3-80

#### 3.1.12.3 Removing the left cover [0007-7554](#)

- 1) Open the front cover [1], and remove the 2 screws [2] on the front side.

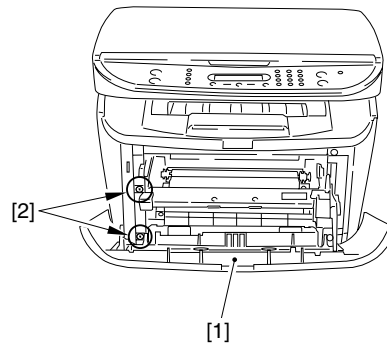

F-3-81

- 2) Remove the 2 screws [1] on the back side, and remove the left cover [2].

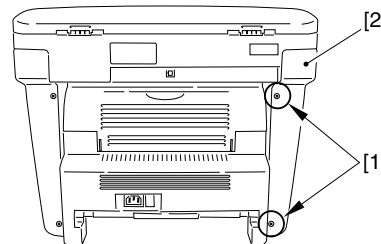

F-3-82

### 3.1.12.4 Removing the front cover

0007-7556

- 1) Open the front cover [1] and remove the arm claws [2] to disengage the connection.
- 2) Remove the shafts on both sides [3] while warping the shaft arms inside, and remove the front cover.

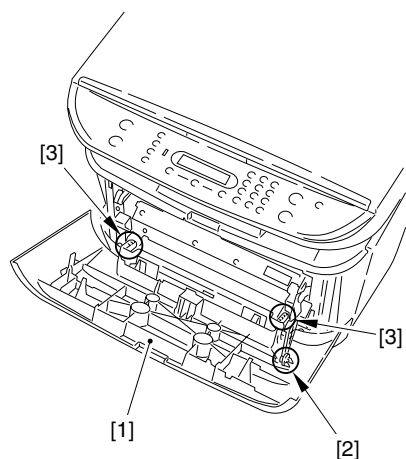

F-3-83

### 3.1.12.5 Removing the rear cover

0007-7557

- 1) Opening the face-up cover [1], and then lower the fixing pressure release levers [2] on both sides and release the pressure.
- 2) Remove 2 screws [3].
- 3) Remove the rear cover [4] as you pull it toward you.

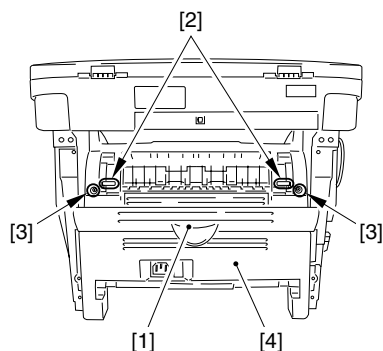

F-3-84

### 3.1.12.6 Removing the Power Supply Shield Plate

0007-7560

- 1) Remove the 9 screws [1] to remove the power supply shield plate [2].

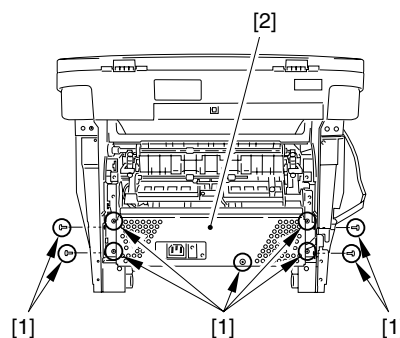

F-3-85

### 3.1.12.7 Removing the Scanner Unit

0007-7561

- 1) Remove the connector [1] and the flat cable [2] on the ECNT board, and remove the screw [3]. (Remove the flat cable from the core.)
- 2) Remove the 2 screws [4] and the 2 pins [5] on the right and left sides.

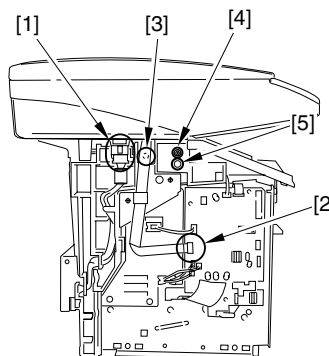

F-3-86

- 3) Remove the 2 screws on the back [1]. Slide the scanner unit [2] to the back; then, remove it by lifting it.

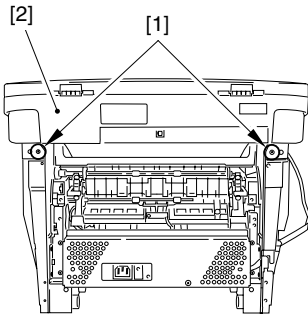

F-3-87

### 3.1.12.8 Removing the Plate 0007-7562

- 1) Remove the connector [1] of the ECNT board.
- 2) Remove the 3 screws [2] and then removes the plate [3].

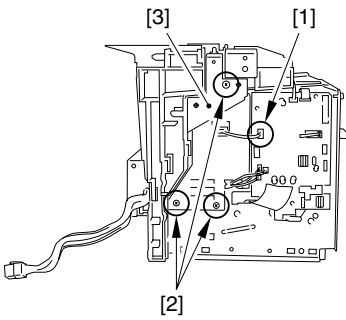

F-3-88

### 3.1.12.9 Removing the Paper

#### Delivery Sensor

0007-7563

- 1) Remove the connector [1] on the ECNT board and take the cable off the cable guide. (The external cover is omitted from the illustration.)
- 2) Remove the screw [2] and remove the paper delivery sensor [3].

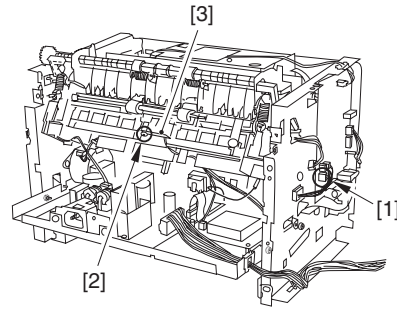

F-3-89

## 3.2 Document Feed/ Exposure System

### 3.2.1 Scanner Unit

#### 3.2.1.1 Removing the Cassette [0002-7555](#)

- 1) Remove the cassette by holding the cassette handle.

#### 3.2.1.2 Removing the right cover [0007-7453](#)

- 1) Open the front cover [1], and remove the 2 screws [2] on the front side.

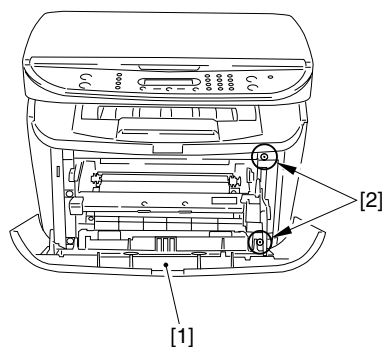

F-3-90

- 2) Remove the 2 screws [1] on the back side, and remove the right cover [2].

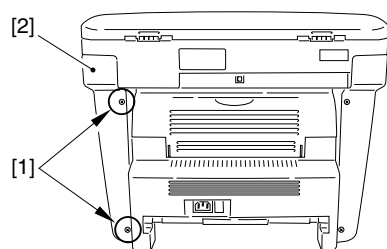

F-3-91

#### 3.2.1.3 Removing the left cover [0007-7454](#)

- 1) Open the front cover [1], and remove the 2 screws [2] on the front side.

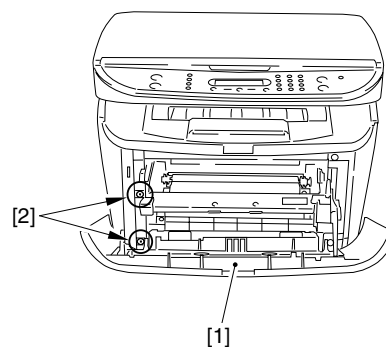

F-3-92

- 2) Remove the 2 screws [1] on the back side, and remove the left cover [2].

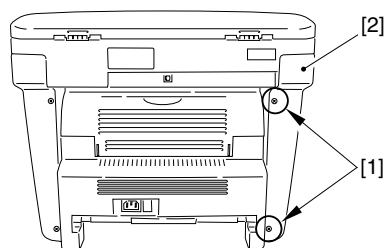

F-3-93

### 3.2.1.4 Removing the rear cover 0007-7455

- 1) Opening the face-up cover [1], and then lower the fixing pressure release levers [2] on both sides and release the pressure.
- 2) Remove 2 screws [3].
- 3) Remove the rear cover [4] as you pull it toward you.

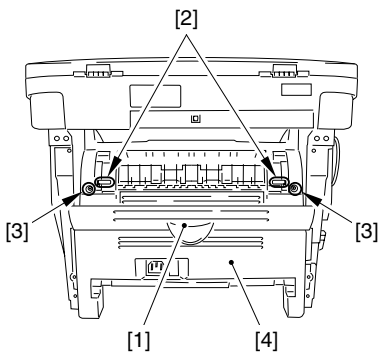

F-3-94

### 3.2.1.5 Removing the Scanner Unit 0007-7457

- 1) Remove the connector [1] and the flat cable [2] on the ECNT board, and remove the screw [3]. (Remove the flat cable from the core.)
- 2) Remove the 2 screws [4] and the 2 pins [5] on the right and left sides.

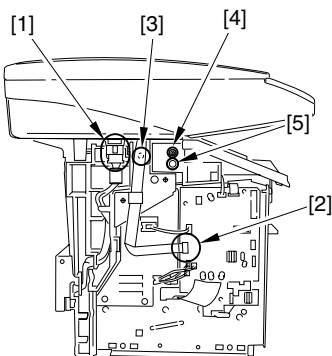

F-3-95

- 3) Remove the 2 screws on the back [1]. Slide the scanner unit [2] to the back; then, remove it by lifting it.

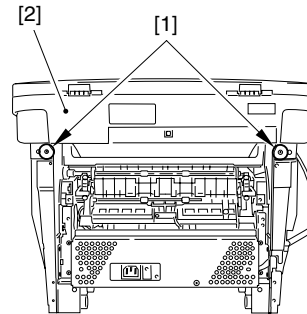

F-3-96

## 3.2.2 Scanner Cover Unit

### 3.2.2.1 Removing the Cassette 0002-7746

- 1) Remove the cassette by holding the cassette handle.

### 3.2.2.2 Removing the right cover 0007-7494

- 1) Open the front cover [1], and remove the 2 screws [2] on the front side.

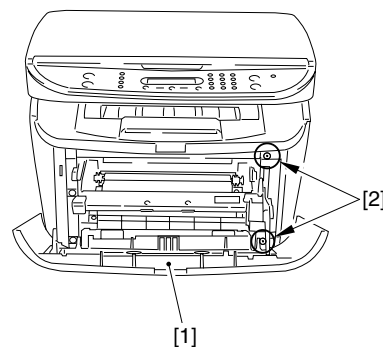

F-3-97



- 2) Remove the 2 screws [1] on the back side, and remove the right cover [2].

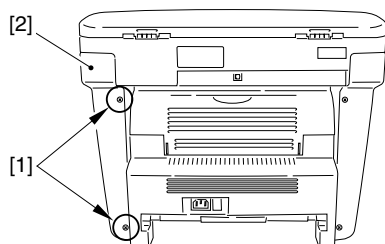

F-3-98

### 3.2.2.3 Removing the left cover [0007-7495](#)

- 1) Open the front cover [1], and remove the 2 screws [2] on the front side.

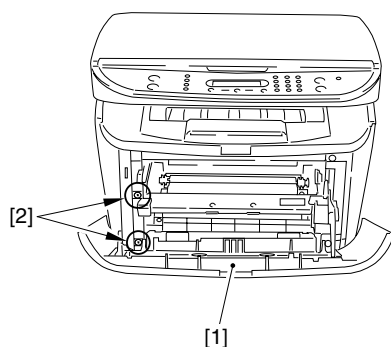

F-3-99

- 2) Remove the 2 screws [1] on the back side, and remove the left cover [2].

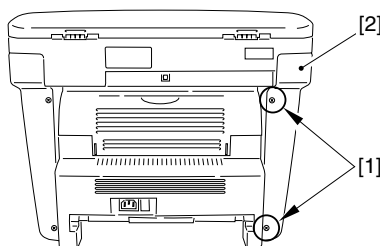

F-3-100

### 3.2.2.4 Removing the rear cover [0007-7496](#)

- 1) Opening the face-up cover [1], and then lower the fixing pressure release levers [2] on both sides and release the pressure.
- 2) Remove 2 screws [3].
- 3) Remove the rear cover [4] as you pull it toward you.

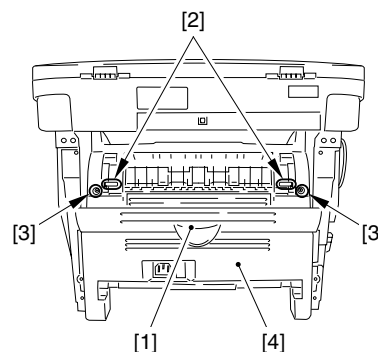

F-3-101

### 3.2.2.5 Removing the Scanner Unit [0007-7497](#)

- 1) Remove the connector [1] and the flat cable [2] on the ECNT board, and remove the screw [3]. (Remove the flat cable from the core.)
- 2) Remove the 2 screws [4] and the 2 pins [5] on the right and left sides.

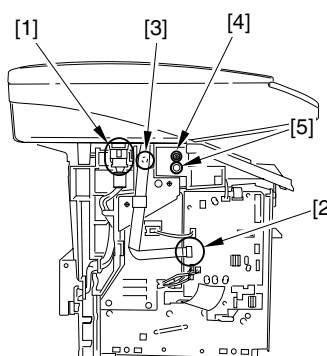

F-3-102

- 3) Remove the 2 screws on the back [1]. Slide the scanner unit [2] to the back; then, remove it by lifting it.

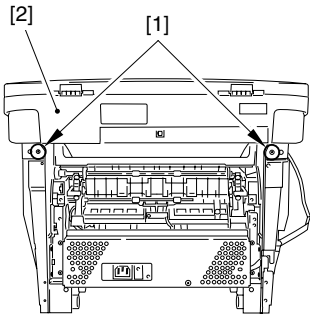

F-3-103

### 3.2.2.6 Removing the Board Unit 0007-7498

- 1) Remove the 4 screws [1] on the back side of the scanner unit.

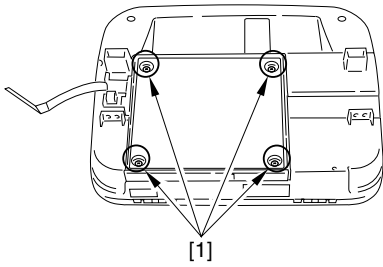

F-3-104

- 2) Open the board unit [1], and remove the connector [2], the grounding cable [3] and the 3 flat cables [4].

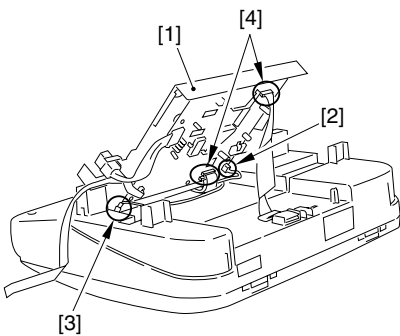

F-3-105

### 3.2.2.7 Removing the Operation Panel Unit 0007-7499

- 1) Remove the 2 screws [1], and remove the flat cable from the core.

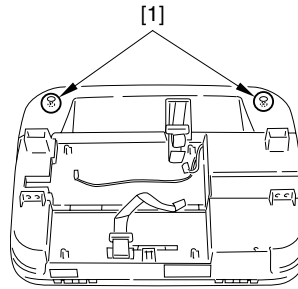

F-3-106

- 2) Remove the 2 claws [2] on the operation panel unit [1], and remove the operation panel unit.

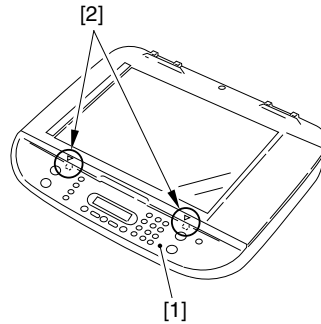

F-3-107

### 3.2.2.8 Removing the Scanner

#### Cover Unit

0007-7500

- 1) Remove the platen glass cover.
- 2) Remove the 3 screws [1].
- 3) Remove the 4 front claws [2] and the 6 claws [3] on the right and left sides, and remove the scanner cover unit.

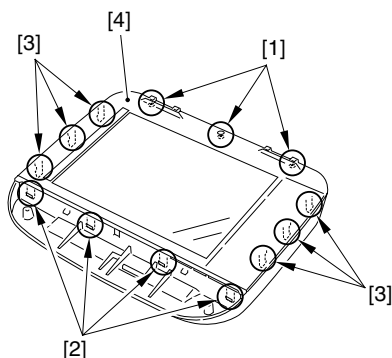

F-3-108

### 3.2.3 CCD Unit

#### 3.2.3.1 Removing the Cassette 0002-7747

- 1) Remove the cassette by holding the cassette handle.

#### 3.2.3.2 Removing the right cover 0007-7516

- 1) Open the front cover [1], and remove the 2 screws [2] on the front side.

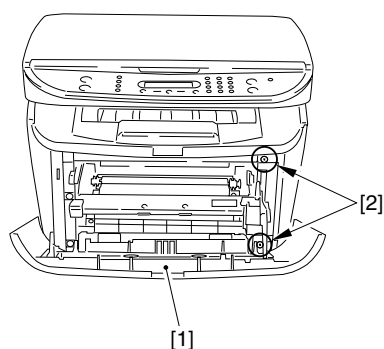

F-3-109

- 2) Remove the 2 screws [1] on the back side, and remove the right cover [2].

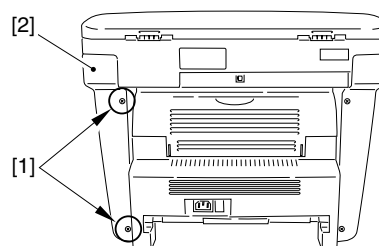

F-3-110

#### 3.2.3.3 Removing the left cover 0007-7517

- 1) Open the front cover [1], and remove the 2 screws [2] on the front side.

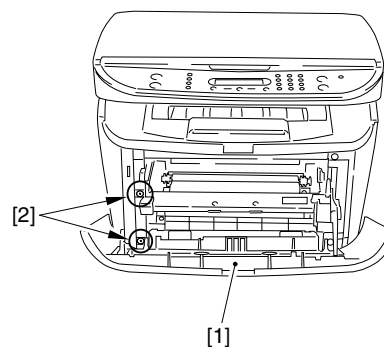

F-3-111

- 2) Remove the 2 screws [1] on the back side, and remove the left cover [2].

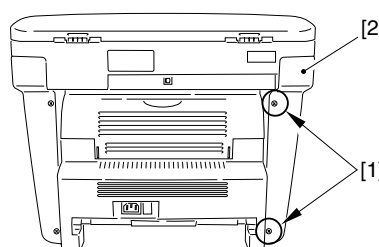

F-3-112

### 3.2.3.4 Removing the rear cover

0007-7518

- 1) Opening the face-up cover [1], and then lower the fixing pressure release levers [2] on both sides and release the pressure.
- 2) Remove 2 screws [3].
- 3) Remove the rear cover [4] as you pull it toward you.

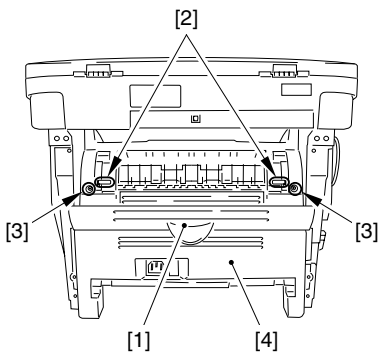

F-3-113

### 3.2.3.5 Removing the Scanner Unit

0007-7519

- 1) Remove the connector [1] and the flat cable [2] on the ECNT board, and remove the screw [3]. (Remove the flat cable from the core.)
- 2) Remove the 2 screws [4] and the 2 pins [5] on the right and left sides.

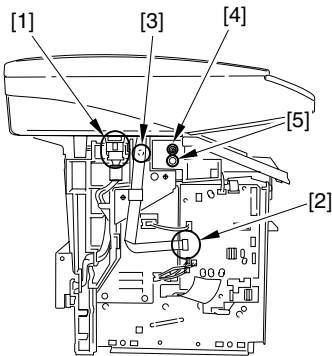

F-3-114

- 3) Remove the 2 screws on the back [1]. Slide the scanner unit [2] to the back; then, remove it by lifting it.

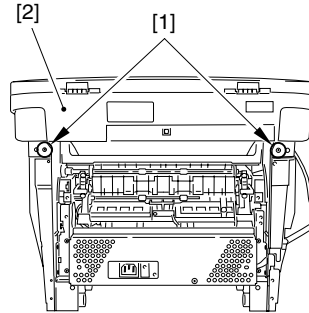

F-3-115

### 3.2.3.6 Removing the Board Unit

0007-7520

- 1) Remove the 4 screws [1] on the back side of the scanner unit.

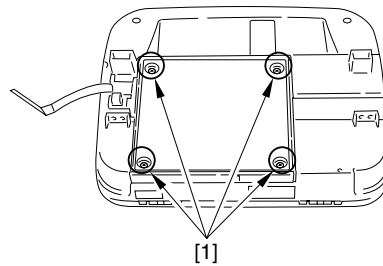

F-3-116

- 2) Open the board unit [1], and remove the connector [2], the grounding cable [3] and the 3 flat cables [4].

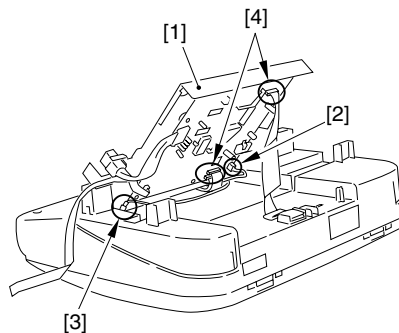

F-3-117

### 3.2.3.7 Removing the Operation Panel Unit 0007-7521

- 1) Remove the 2 screws [1], and remove the flat cable from the core.

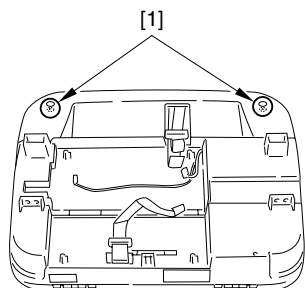

F-3-118

- 2) Remove the 2 claws [2] on the operation panel unit [1], and remove the operation panel unit.

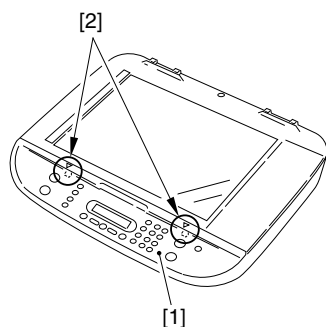

F-3-119

### 3.2.3.8 Removing the Scanner Cover Unit 0007-7522

- 1) Remove the platen glass cover.
- 2) Remove the 3 screws [1].
- 3) Remove the 4 front claws [2] and the 6 claws [3] on the right and left sides, and remove the scanner cover unit.

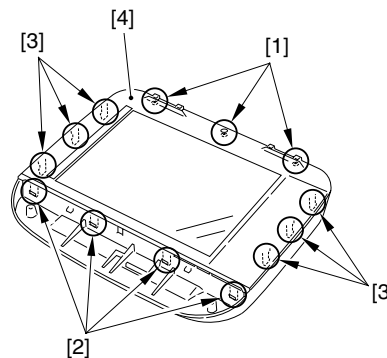

F-3-120

### 3.2.3.9 Removing the Flatbed Motor Unit 0007-7523

- 1) Remove the 2 screws [1].
- 2) While watching the CCD unit drive belt [2] carefully, remove the flatbed motor unit [3].

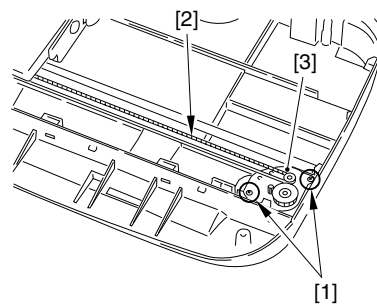

F-3-121

### 3.2.3.10 Removing the CCD

Unit 0007-7524

- 1) Slide the core [2] while releasing the stopper [1].
- 2) Remove the flat cable [3].
- 3) Lift the right side of the shaft [4] to release the stop. Then slide it to release the stop on the left side also.
- 4) Remove the CCD unit [5] by pulling it out of the shaft.

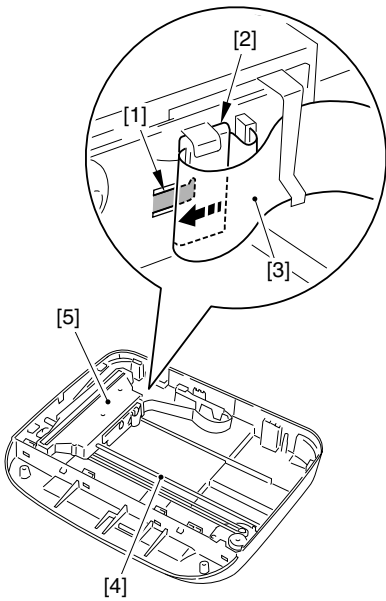

F-3-122

## 3.2.4 Flatbed Motor Unit

### 3.2.4.1 Removing the Cassette 0002-7748

- 1) Remove the cassette by holding the cassette handle.

### 3.2.4.2 Removing the right cover

0007-7502

- 1) Open the front cover [1], and remove the 2 screws [2] on the front side.

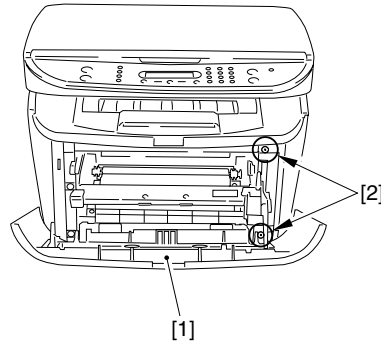

F-3-123

- 2) Remove the 2 screws [1] on the back side, and remove the right cover [2].

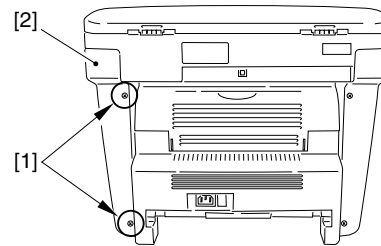

F-3-124

### 3.2.4.3 Removing the left cover 0007-7503

- 1) Open the front cover [1], and remove the 2 screws [2] on the front side.

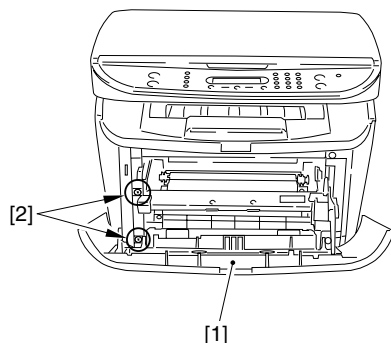

F-3-125

- 2) Remove the 2 screws [1] on the back side, and remove the left cover [2].

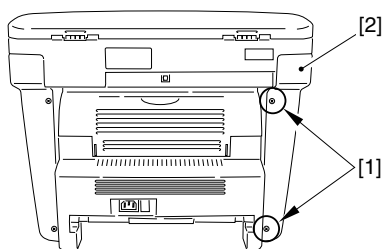

F-3-126

### 3.2.4.4 Removing the rear cover 0007-7505

- 1) Opening the face-up cover [1], and then lower the fixing pressure release levers [2] on both sides and release the pressure.
- 2) Remove 2 screws [3].
- 3) Remove the rear cover [4] as you pull it toward you.

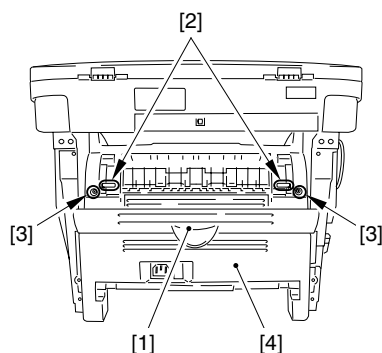

F-3-127

### 3.2.4.5 Removing the Scanner

Unit 0007-7506

- 1) Remove the connector [1] and the flat cable [2] on the ECNT board, and remove the screw [3]. (Remove the flat cable from the core.)
- 2) Remove the 2 screws [4] and the 2 pins [5] on the right and left sides.

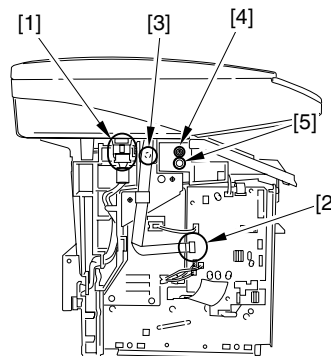

F-3-128

- 3) Remove the 2 screws on the back [1]. Slide the scanner unit [2] to the back; then, remove it by lifting it.

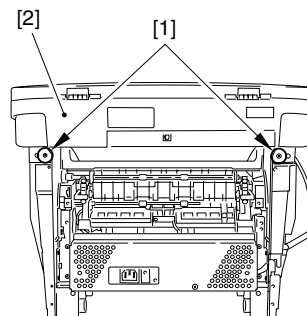

F-3-129

### 3.2.4.6 Removing the Board

Unit 0007-7507

- 1) Remove the 4 screws [1] on the back side of the scanner unit.

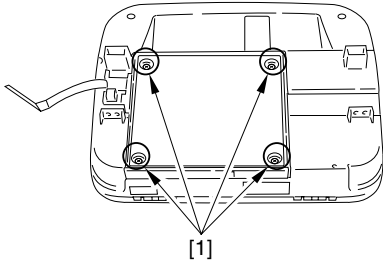

F-3-130

- 2) Open the board unit [1], and remove the connector [2], the grounding cable [3] and the 3 flat cables [4].

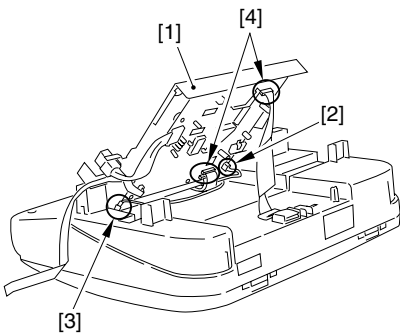

F-3-131

### 3.2.4.7 Removing the Operation Panel Unit

0007-7509

- 1) Remove the 2 screws [1], and remove the flat cable from the core.

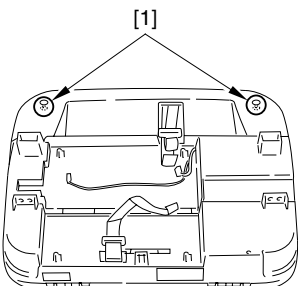

F-3-132

- 2) Remove the 2 claws [2] on the operation panel unit [1], and remove the operation panel unit.

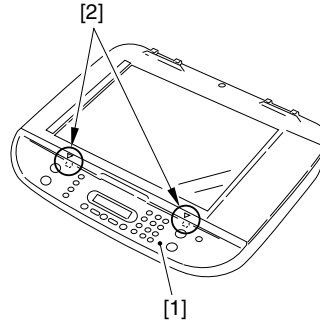

F-3-133

### 3.2.4.8 Removing the Scanner

Cover Unit 0007-7511

- 1) Remove the platen glass cover.
- 2) Remove the 3 screws [1].
- 3) Remove the 4 front claws [2] and the 6 claws [3] on the right and left sides, and remove the scanner cover unit.

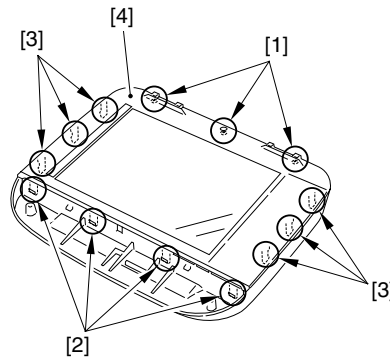

F-3-134



### 3.2.4.9 Removing the Flatbed

Motor Unit

0007-7512

- 1) Remove the 2 screws [1].
- 2) While watching the CCD unit drive belt [2] carefully, remove the flatbed motor unit [3].

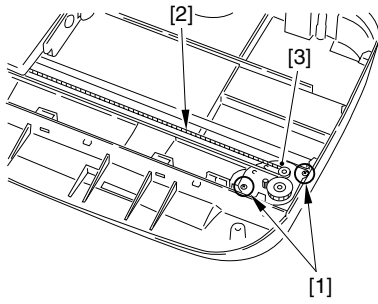

F-3-135

## 3.3 LASER EXPOSURE SYSTEM

### 3.3.1 Laser/Scanner Unit

#### 3.3.1.1 Removing the Cassette 0002-7542

- 1) Remove the cassette by holding the cassette handle.

#### 3.3.1.2 Removing the right cover 0007-7768

- 1) Open the front cover [1], and remove the 2 screws [2] on the front side.

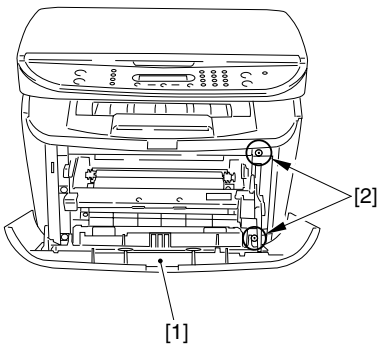

F-3-136

- 2) Remove the 2 screws [1] on the back side, and remove the right cover [2].

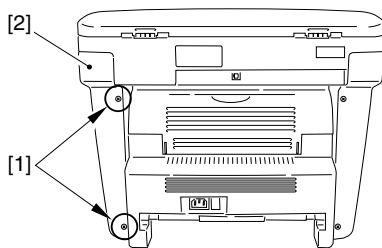

F-3-137

#### 3.3.1.3 Removing the left cover 0007-7769

- 1) Open the front cover [1], and remove the 2 screws [2] on the front side.

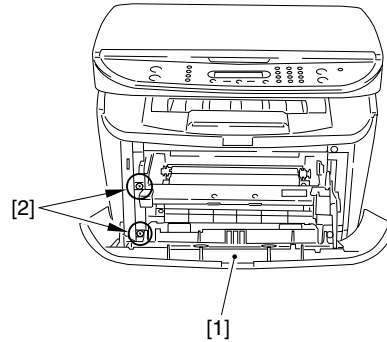

F-3-138

- 2) Remove the 2 screws [1] on the back side, and remove the left cover [2].

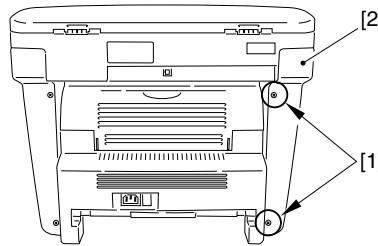

F-3-139

### 3.3.1.4 Removing the rear cover

0007-7770

- 1) Opening the face-up cover [1], and then lower the fixing pressure release levers [2] on both sides and release the pressure.
- 2) Remove 2 screws [3].
- 3) Remove the rear cover [4] as you pull it toward you.

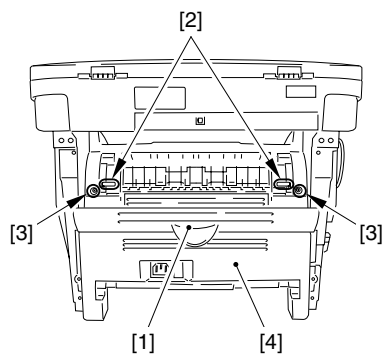

F-3-140

### 3.3.1.5 Removing the Scanner Unit

0007-7771

- 1) Remove the connector [1] and the flat cable [2] on the ECNT board, and remove the screw [3]. (Remove the flat cable from the core.)
- 2) Remove the 2 screws [4] and the 2 pins [5] on the right and left sides.

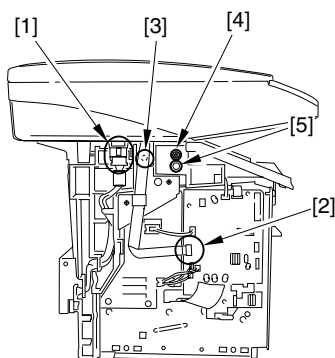

F-3-141

- 3) Remove the 2 screws on the back [1]. Slide the scanner unit [2] to the back; then, remove it by lifting it.

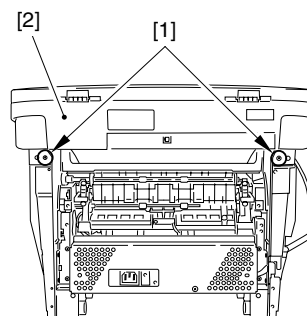

F-3-142

### 3.3.1.6 Removing the Top Cover

0007-7772

- 1) Remove the 2 screws [1], and remove the Top cover [2].

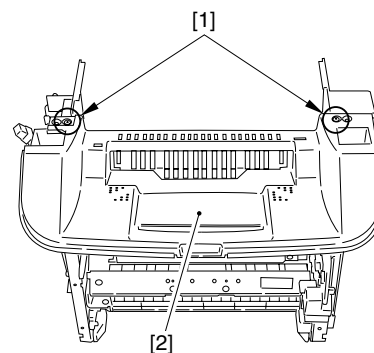

F-3-143

### 3.3.1.7 Removing the Laser/

#### Scanner Unit

0007-7773

- 1) Remove the connector [1] of the ECNT board.  
Take the cable off the cable clamp. (The external cover is omitted from the illustration below to show the instructions clearly.)
- 2) Take the flat cable [2] off the board of the laser/ scanner unit.
- 3) Remove the 4 screws [3] to remove the laser/ scanner unit [4]. Ensure that the grounding plate [5] does not get lost.

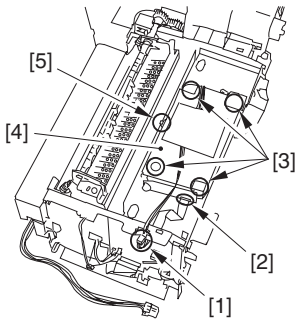

F-3-144

---

## 3.4 IMAGE FORMATION SYSTEM

---

### 3.4.1 Transfer Charging Roller

#### 3.4.1.1 Removing the Transfer

Charging Roller 0007-7699

- 1) Open the front cover.
- 2) Hold the 2 claws [1] on the right side of the roller, lifting them up.
- 3) Slide the transfer charging roller [2] by sliding it to the right.

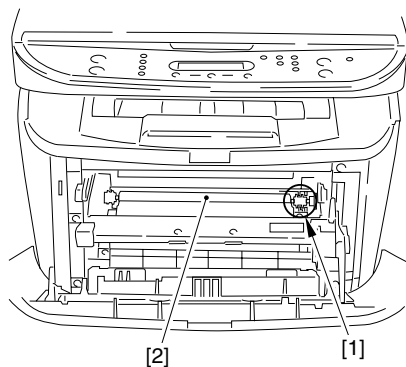

F-3-145

## 3.5 PICKUP AND FEEDING SYSTEM

### 3.5.1 Cassette Pickup Roller

#### 3.5.1.1 Removing the Cassette 0002-7053

- 1) Remove the cassette by holding the cassette handle.

#### 3.5.1.2 Removing the right cover 0007-7800

- 1) Open the front cover [1], and remove the 2 screws [2] on the front side.

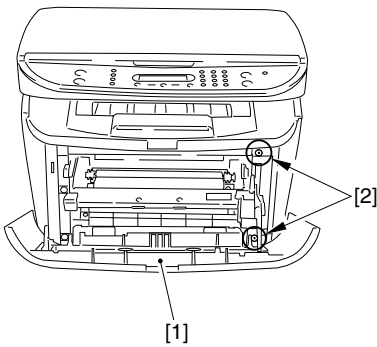

F-3-146

- 2) Remove the 2 screws [1] on the back side, and remove the right cover [2].

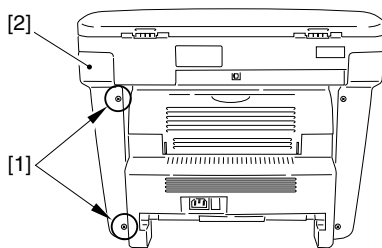

F-3-147

#### 3.5.1.3 Removing the left cover 0007-7801

- 1) Open the front cover [1], and remove the 2 screws [2] on the front side.

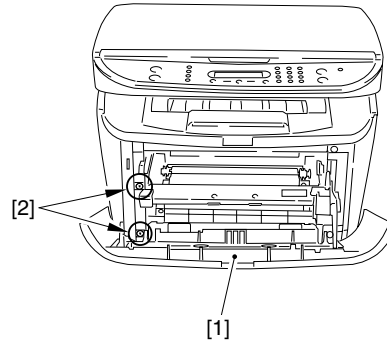

F-3-148

- 2) Remove the 2 screws [1] on the back side, and remove the left cover [2].

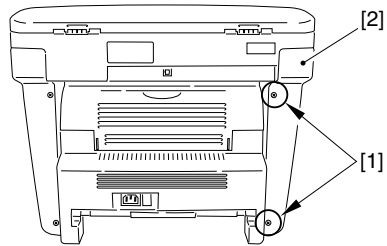

F-3-149

### 3.5.1.4 Removing the front cover

0007-7802

- 1) Open the front cover [1] and remove the arm claws [2] to disengage the connection.
- 2) Remove the shafts on both sides [3] while warping the shaft arms inside, and remove the front cover.

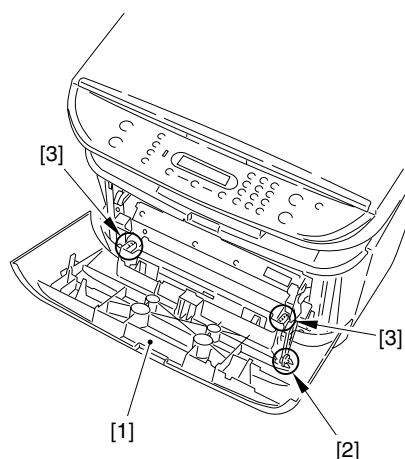

F-3-150

### 3.5.1.5 Removing the rear cover

0007-7804

- 1) Opening the face-up cover [1], and then lower the fixing pressure release levers [2] on both sides and release the pressure.
- 2) Remove 2 screws [3].
- 3) Remove the rear cover [4] as you pull it toward you.

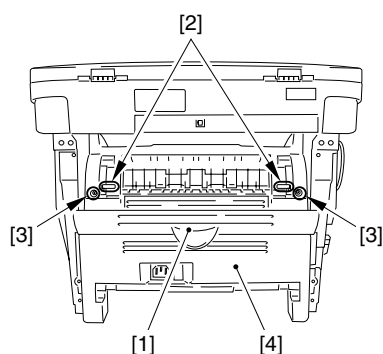

F-3-151

### 3.5.1.6 Removing the Scanner Unit

0007-7805

- 1) Remove the connector [1] and the flat cable [2] on the ECNT board, and remove the screw [3]. (Remove the flat cable from the core.)
- 2) Remove the 2 screws [4] and the 2 pins [5] on the right and left sides.

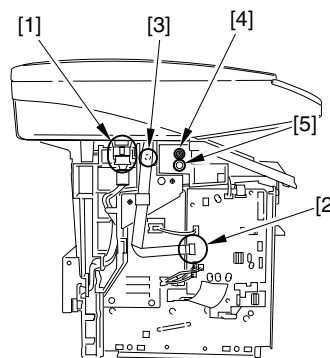

F-3-152

- 3) Remove the 2 screws on the back [1]. Slide the scanner unit [2] to the back; then, remove it by lifting it.

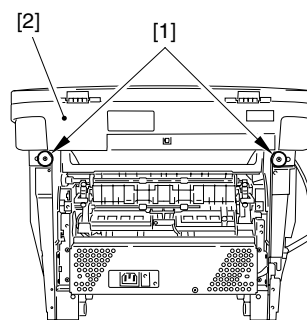

F-3-153

### 3.5.1.7 Removing the Top Cover

0007-7807

- 1) Remove the 2 screws [1], and remove the Top cover [2].

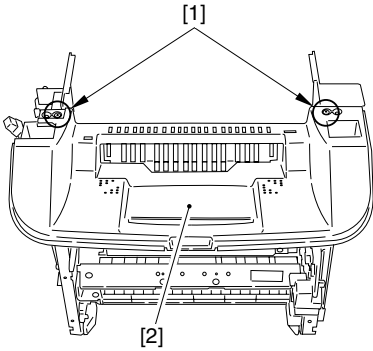

F-3-154

### 3.5.1.8 Removing the Right Frame

0007-7808

- 1) Remove the 3 screws [1], and remove the right frame [2].

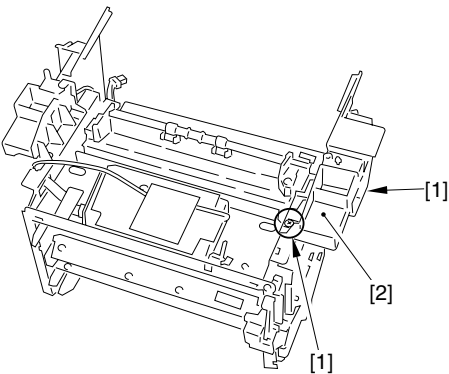

F-3-155

### 3.5.1.9 Removing the Plate

0007-7809

- 1) Remove the connector [1] of the ECNT board.
- 2) Remove the 3 screws [2] and then removes the plate [3].

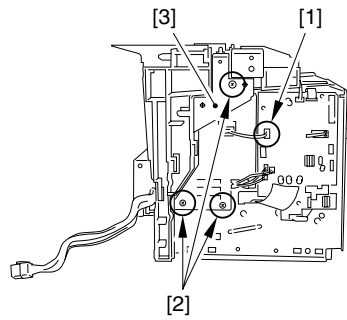

F-3-156

### 3.5.1.10 Removing the Left Frame

0007-7811

- 1) Remove the cable [1] from the cable guide.
- 2) Remove the 2 screws [2], and remove the left frame [3].

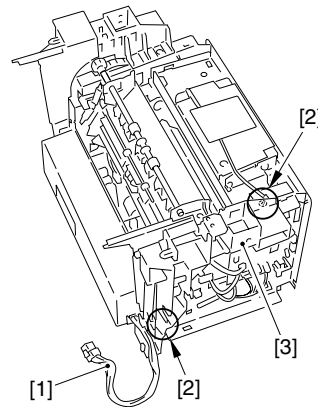

F-3-157



### 3.5.1.11 Removing the Power

#### Supply Shield Plate 0007-7813

- 1) Remove the 5 screws [1] to remove the power supply shield plate [2].

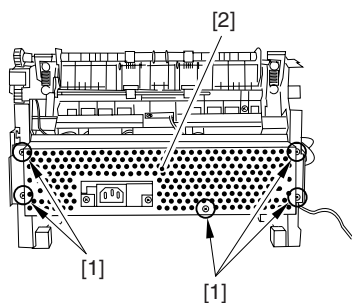

F-3-158

### 3.5.1.12 Removing the Power

#### Supply Assembly 0007-7816

- 1) Remove the 3 screws [1].
- 2) Remove the 4 connectors [2] as well as the flat cable [3] on the ECNT board.

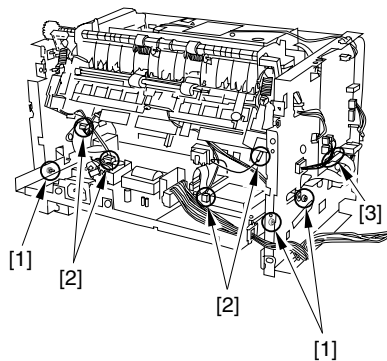

F-3-159

- 3) As you remove the bosses on both sides [1], lower the front part of the power supply assembly [2]. Then pull it to remove the power supply assembly.

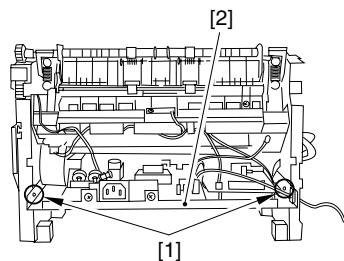

F-3-160

### 3.5.1.13 Removing the Gear

#### Unit 0007-7818

- 1) Remove the 2 screws [1], and detach the drive plate (small) [2].

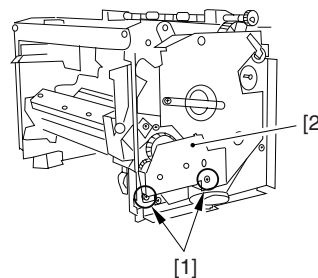

F-3-161

- 2) Remove the 2 gears [1].
- 3) While freeing the claw, detach the gear unit [2].

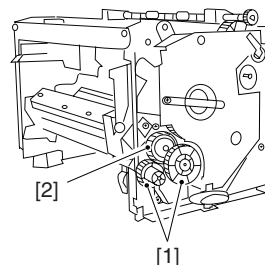

F-3-162

### 3.5.1.14 Removing the Tooth-Missing Gear

0007-7819

- 1) Remove the 2 screws [1], and detach the gear support [2].

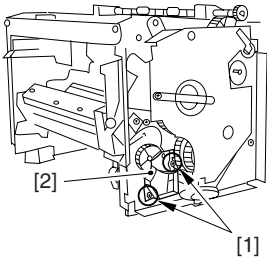

F-3-163

- 2) Remove the spring [1].
- 3) While freeing the claw, detach the tooth-missing gear [2].

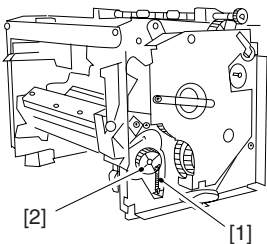

F-3-164

### 3.5.1.15 Removing the Cassette Pickup Roller

0007-7820

- 1) Place the main unit down on its front face (so that the interior of the main unit is easily visible).
- 2) Remove the boss of the bushing [1], and turn it to the front; then, slide it to detach the bushing.
- 3) Slide the pickup roller [2] to remove it.

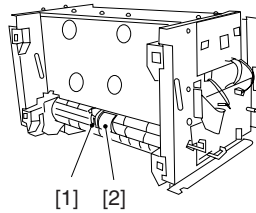

F-3-165

## 3.5.2 Cassette Pickup Solenoid

### 3.5.2.1 Removing the Cassette 0002-7055

- 1) Remove the cassette by holding the cassette handle.

### 3.5.2.2 Removing the right cover 0007-7823

- 1) Open the front cover [1], and remove the 2 screws [2] on the front side.

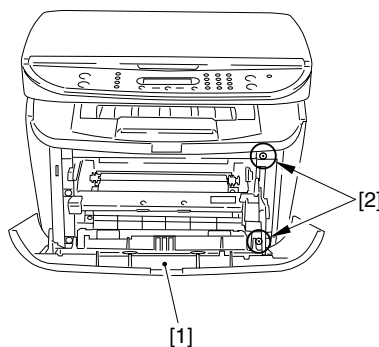

F-3-166

- 2) Remove the 2 screws [1] on the back side, and remove the right cover [2].

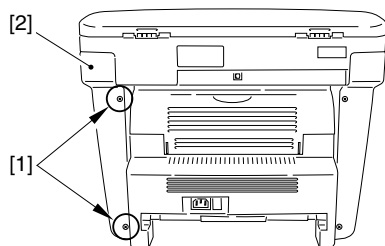

F-3-167

### 3.5.2.3 Removing the left cover [0007-7824](#)

- 1) Open the front cover [1], and remove the 2 screws [2] on the front side.

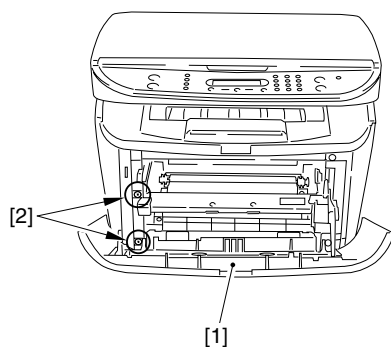

F-3-168

- 2) Remove the 2 screws [1] on the back side, and remove the left cover [2].

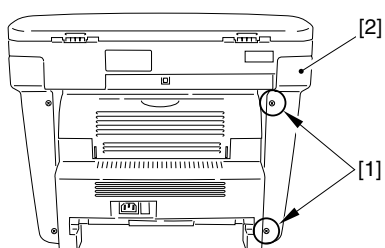

F-3-169

### 3.5.2.4 Removing the front cover [0007-7825](#)

- 1) Open the front cover [1] and remove the arm claws [2] to disengage the connection.  
2) Remove the shafts on both sides [3] while warping the shaft arms inside, and remove the front cover.

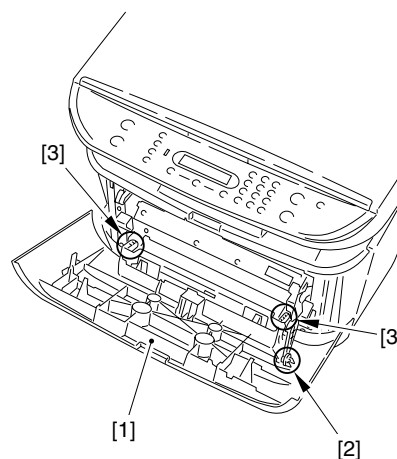

F-3-170

### 3.5.2.5 Removing the rear cover [0007-7826](#)

- 1) Opening the face-up cover [1], and then lower the fixing pressure release levers [2] on both sides and release the pressure.  
2) Remove 2 screws [3].  
3) Remove the rear cover [4] as you pull it toward you.

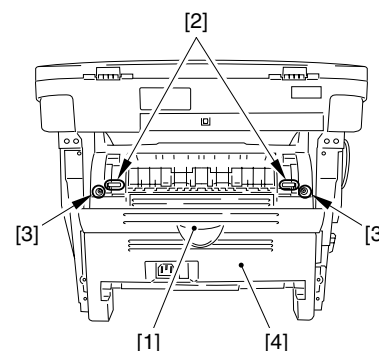

F-3-171

### 3.5.2.6 Removing the Scanner

Unit 0007-7827

- 1) Remove the connector [1] and the flat cable [2] on the ECNT board, and remove the screw [3]. (Remove the flat cable from the core.)
- 2) Remove the 2 screws [4] and the 2 pins [5] on the right and left sides.

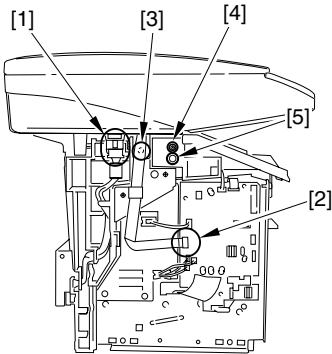

F-3-172

- 3) Remove the 2 screws on the back [1]. Slide the scanner unit [2] to the back; then, remove it by lifting it.

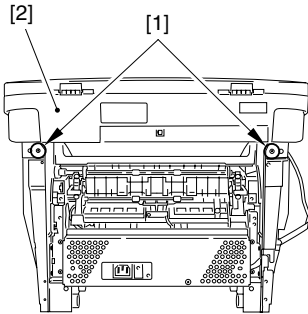

F-3-173

### 3.5.2.7 Removing the Top Cover 0007-7828

- 1) Remove the 2 screws [1], and remove the Top cover [2].

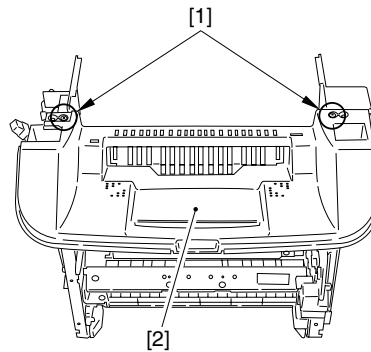

F-3-174

### 3.5.2.8 Removing the Right Frame 0007-7829

- 1) Remove the 3 screws [1], and remove the right frame [2].

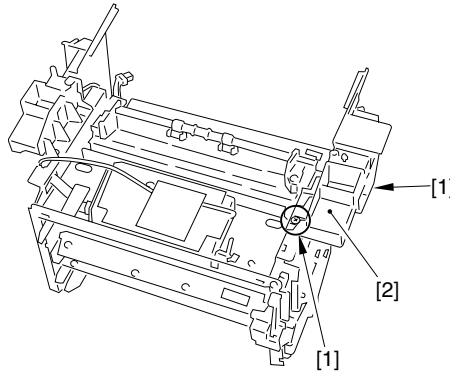

F-3-175

### 3.5.2.9 Removing the Plate 0007-7830

- 1) Remove the connector [1] of the ECNT board.
- 2) Remove the 3 screws [2] and then removes the plate [3].

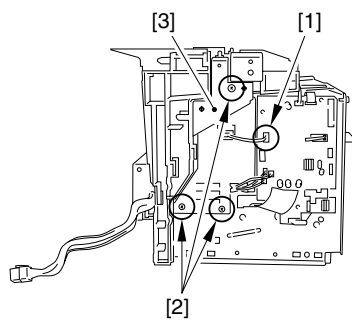

F-3-176

### 3.5.2.10 Removing the Left Frame 0007-7831

- 1) Remove the cable [1] from the cable guide.
- 2) Remove the 2 screws [2], and remove the left frame [3].

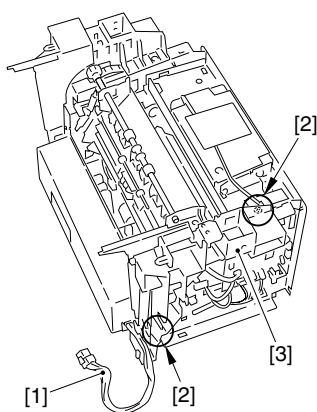

F-3-177

### 3.5.2.11 Removing the Power Supply Shield Plate 0007-9963

- 1) Remove the 5 screws [1] to remove the power supply shield plate [2].

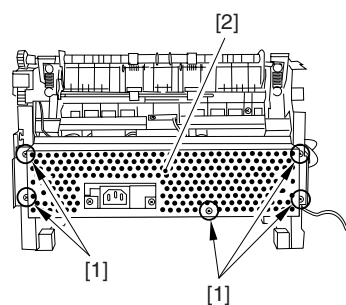

F-3-178

### 3.5.2.12 Removing the Power Supply Assembly 0007-7832

- 1) Remove the 3 screws [1].
- 2) Remove the 4 connectors [2] as well as the flat cable [3] on the ECNT board.

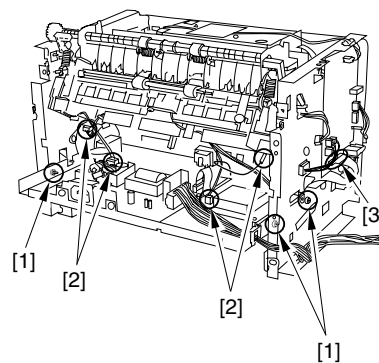

F-3-179

- 3) As you remove the bosses on both sides [1], lower the front part of the power supply assembly [2]. Then pull it to remove the power supply assembly.

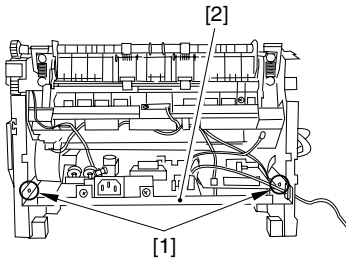

F-3-180

### 3.5.2.13 Removing the Cassette

#### Pickup Solenoid 0007-7833

- 1) Place the main unit down on its front face (so that the interior of the main unit is easily visible).
- 2) Remove the connector [1] on the ECNT board and take out the cable from the cable guide.
- 3) Remove the screw [2] to remove the cassette pickup solenoid [3], which is located behind the main motor.

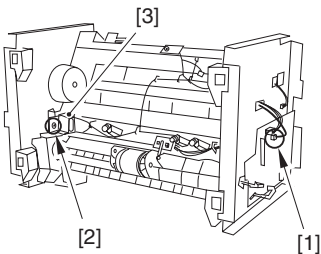

F-3-181

## 3.5.3 Cassette Separation Pad

### 3.5.3.1 Removing the Rear of the Cassette 0002-3783

- 1) Lift the rear of the cassette, and separate the rear from the front.

### 3.5.3.2 Removing the Cassette

#### Separation Pad 0007-7881

- 1) Remove the shafts [1] on both sides of the lifting plate. Remove the lifting plate [3] while watching the lifting plate spring [2] carefully.

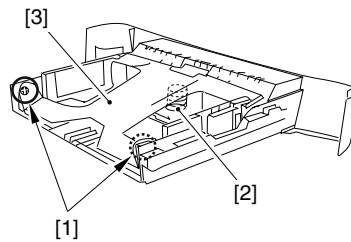

F-3-182

- 2) Remove the 2 claws [1] on both sides of the cassette separation pad and lift it up while watching the lifting plate spring [2] carefully. Ensure that the separation pad spring does not get lost.
- 3) Remove both the plate and the cassette separation pad [3] by sliding them to the left.

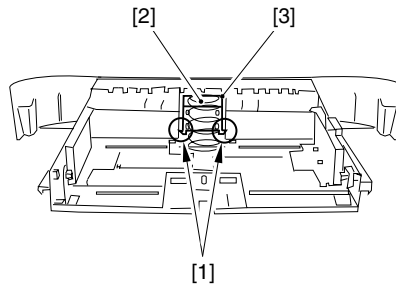

F-3-183

- 4) Remove the 2 claws [1] and remove the cassette separation pad [2] by sliding it up.

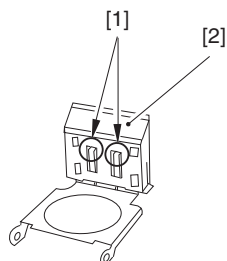

F-3-184

### 3.5.4 Paper Feed Roller

#### 3.5.4.1 Removing the Cassette 0002-7105

- 1) Remove the cassette by holding the cassette handle.

#### 3.5.4.2 Removing the right cover 0007-7835

- 1) Open the front cover [1], and remove the 2 screws [2] on the front side.

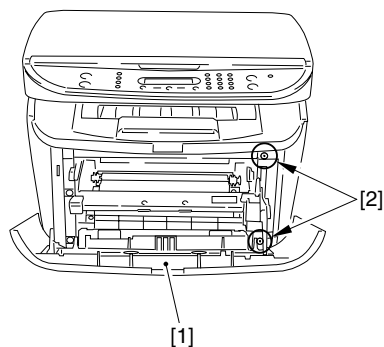

F-3-185

- 2) Remove the 2 screws [1] on the back side, and remove the right cover [2].

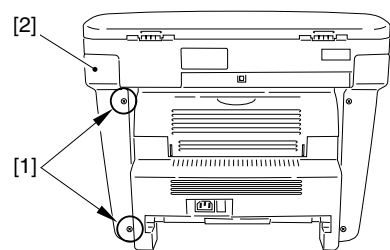

F-3-186

#### 3.5.4.3 Removing the left cover 0007-7836

- 1) Open the front cover [1], and remove the 2 screws [2] on the front side.

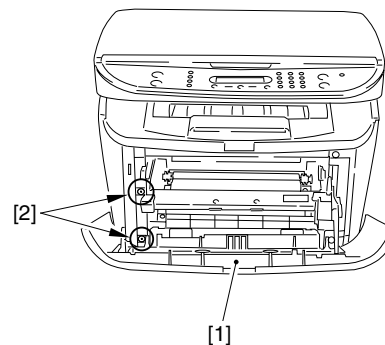

F-3-187

- 2) Remove the 2 screws [1] on the back side, and remove the left cover [2].

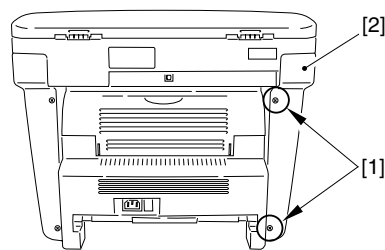

F-3-188

### 3.5.4.4 Removing the front cover

0007-7838

- 1) Open the front cover [1] and remove the arm claws [2] to disengage the connection.
- 2) Remove the shafts on both sides [3] while warping the shaft arms inside, and remove the front cover.

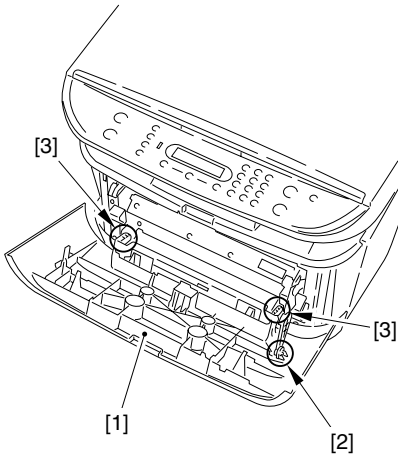

F-3-189

### 3.5.4.5 Removing the rear cover

0007-7839

- 1) Opening the face-up cover [1], and then lower the fixing pressure release levers [2] on both sides and release the pressure.
- 2) Remove 2 screws [3].
- 3) Remove the rear cover [4] as you pull it toward you.

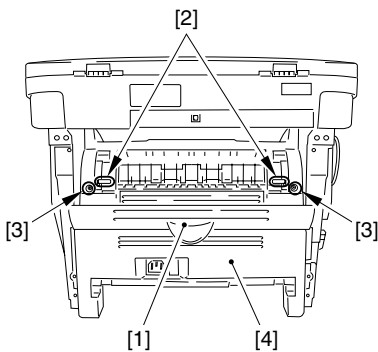

F-3-190

### 3.5.4.6 Removing the Scanner Unit

0007-7845

- 1) Remove the connector [1] and the flat cable [2] on the ECNT board, and remove the screw [3]. (Remove the flat cable from the core.)
- 2) Remove the 2 screws [4] and the 2 pins [5] on the right and left sides.

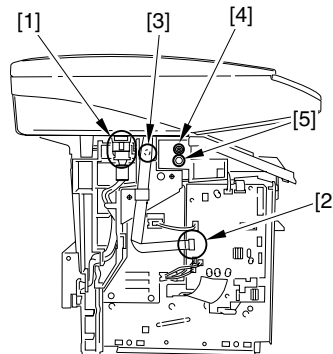

F-3-191

- 3) Remove the 2 screws on the back [1]. Slide the scanner unit [2] to the back; then, remove it by lifting it.

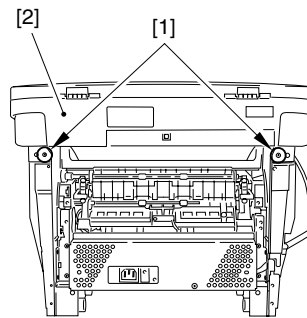

F-3-192



### 3.5.4.7 Removing the Top

Cover 0007-7846

- 1) Remove the 2 screws [1], and remove the Top cover [2].

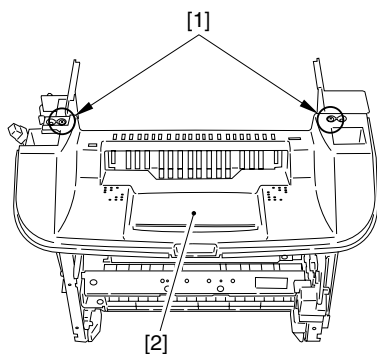

F-3-193

### 3.5.4.8 Removing the Right

Frame 0007-7847

- 1) Remove the 3 screws [1], and remove the right frame [2].

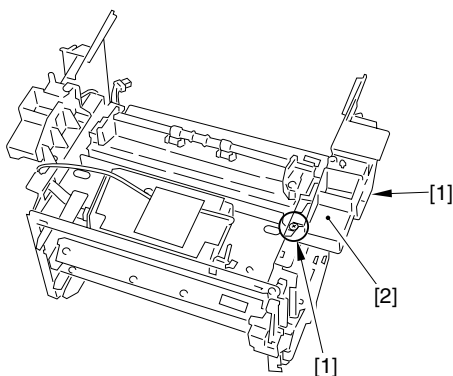

F-3-194

### 3.5.4.9 Removing the Plate

0007-7848

- 1) Remove the connector [1] of the ECNT board.
- 2) Remove the 3 screws [2] and then removes the plate [3].

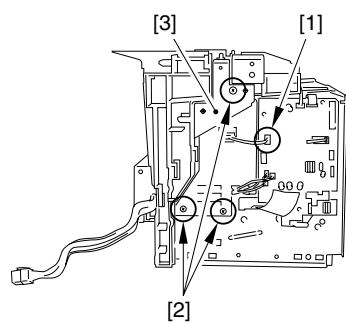

F-3-195

### 3.5.4.10 Removing the Left

Frame 0007-7849

- 1) Remove the cable [1] from the cable guide.
- 2) Remove the 2 screws [2], and remove the left frame [3].

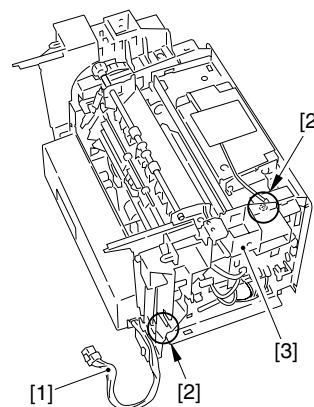

F-3-196

### 3.5.4.11 Removing the Power

#### Supply Shield Plate 0007-7851

- 1) Remove the 5 screws [1] to remove the power supply shield plate [2].

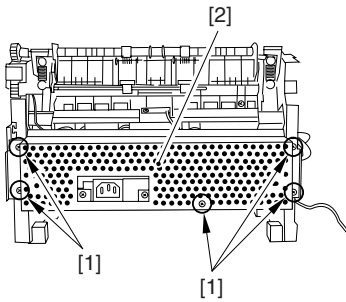

F-3-197

### 3.5.4.12 Removing the Power

#### Supply Assembly 0007-7852

- 1) Remove the 3 screws [1].
- 2) Remove the 4 connectors [2] as well as the flat cable [3] on the ECNT board.

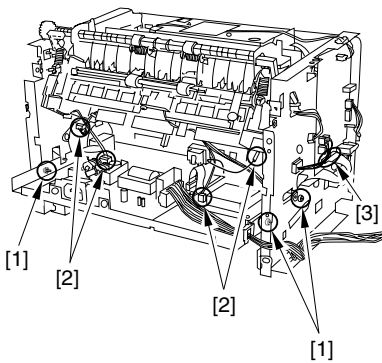

F-3-198

- 3) As you remove the bosses on both sides [1], lower the front part of the power supply assembly [2]. Then pull it to remove the power supply assembly.

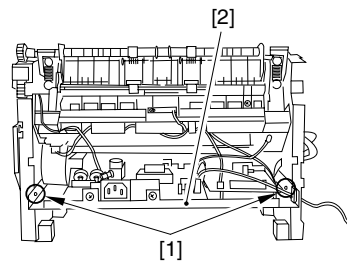

F-3-199

### 3.5.4.13 Removing the Gear

#### Unit 0007-7853

- 1) Remove the 2 screws [1], and detach the drive plate (small) [2].

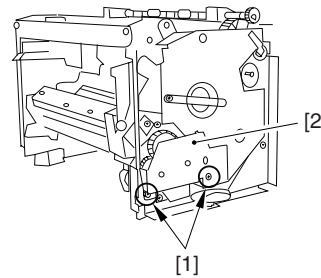

F-3-200

- 2) Remove the 2 gears [1].
- 3) While freeing the claw, detach the gear unit [2].

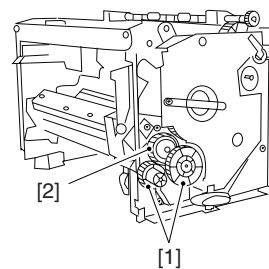

F-3-201

### 3.5.4.14 Removing the Tooth-Missing Gear

0007-7854

- 1) Remove the 2 screws [1], and detach the gear support [2].

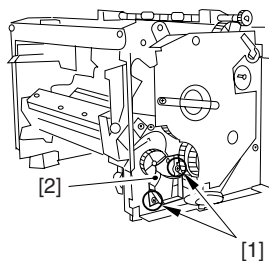

F-3-202

- 2) Remove the spring [1].
- 3) While freeing the claw, detach the tooth-missing gear [2].

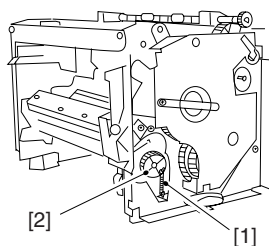

F-3-203

### 3.5.4.15 Removing the Manual Stay

0007-7855

- 1) Release the lower claw [2] of the solenoid cover [1], and remove the solenoid cover.

- 2) Remove the 3 screws [3]. While watching the sensor flag carefully, remove the manual stay [4].

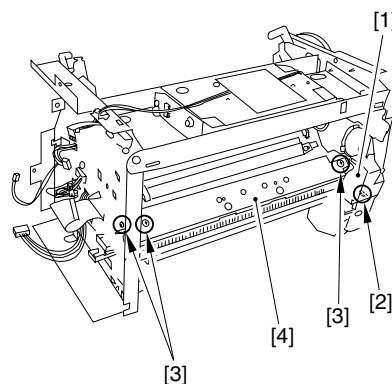

F-3-204

### 3.5.4.16 Removing the Paper Feed Guide

0007-7856

- 1) Remove the screw [1], and detach the paper feed guide [2].

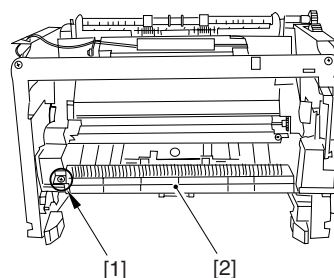

F-3-205

### 3.5.4.17 Removing the Paper

#### Feed Roller

0007-7857

- 1) Lift the left side of the paper feed roller [1], and slide it to detach.

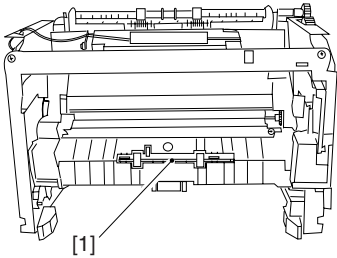

F-3-206

## 3.5.5 Manual Pickup Solenoid

### 3.5.5.1 Removing the Cassette 0002-7106

- 1) Remove the cassette by holding the cassette handle.

### 3.5.5.2 Removing the right cover

0007-7858

- 1) Open the front cover [1], and remove the 2 screws [2] on the front side.

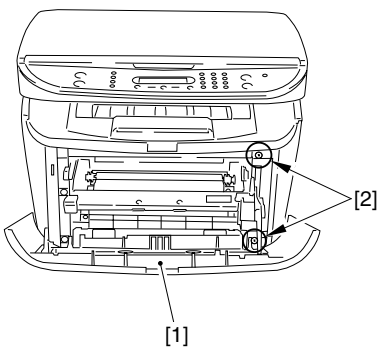

F-3-207

- 2) Remove the 2 screws [1] on the back side, and remove the right cover [2].

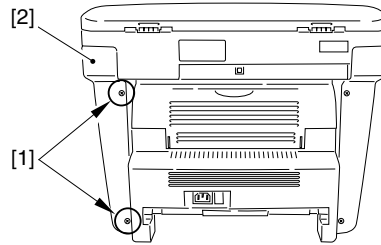

F-3-208

### 3.5.5.3 Removing the left cover 0007-7859

- 1) Open the front cover [1], and remove the 2 screws [2] on the front side.

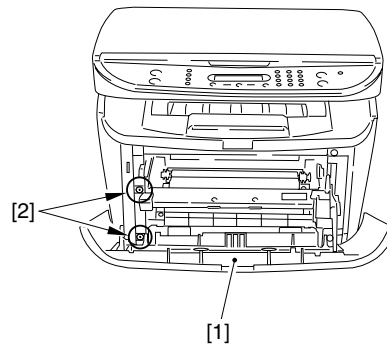

F-3-209

- 2) Remove the 2 screws [1] on the back side, and remove the left cover [2].

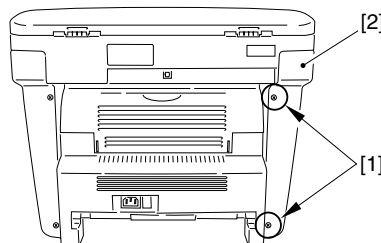

F-3-210

### 3.5.5.4 Removing the front cover 0007-7861

- 1) Open the front cover [1] and remove the arm claws [2] to disengage the connection.
- 2) Remove the shafts on both sides [3] while warping the shaft arms inside, and remove the front cover.

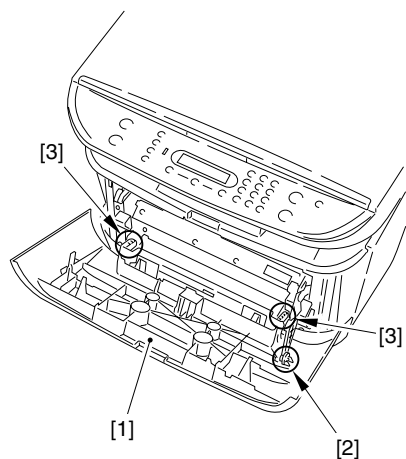

F-3-211

### 3.5.5.5 Removing the rear cover 0007-7862

- 1) Opening the face-up cover [1], and then lower the fixing pressure release levers [2] on both sides and release the pressure.
- 2) Remove 2 screws [3].
- 3) Remove the rear cover [4] as you pull it toward you.

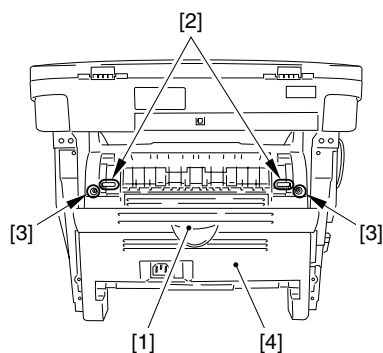

F-3-212

### 3.5.5.6 Removing the Scanner

Unit 0007-7863

- 1) Remove the connector [1] and the flat cable [2] on the ECNT board, and remove the screw [3]. (Remove the flat cable from the core.)
- 2) Remove the 2 screws [4] and the 2 pins [5] on the right and left sides.

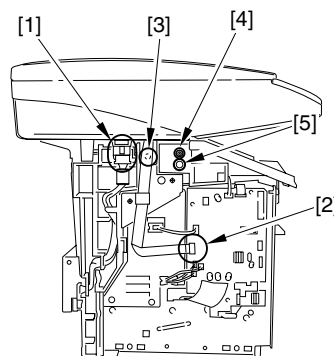

F-3-213

- 3) Remove the 2 screws on the back [1]. Slide the scanner unit [2] to the back; then, remove it by lifting it.

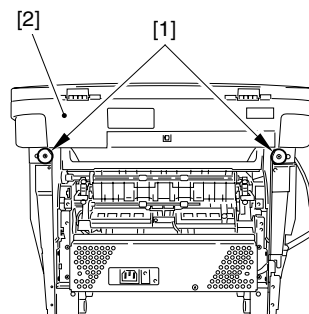

F-3-214

### 3.5.5.7 Removing the Top Cover

0007-7865

- 1) Remove the 2 screws [1], and remove the Top cover [2].

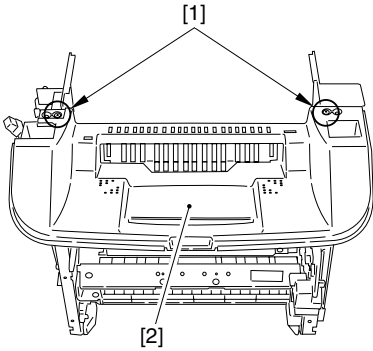

F-3-215

### 3.5.5.8 Removing the Right Frame

0007-7866

- 1) Remove the 3 screws [1], and remove the right frame [2].

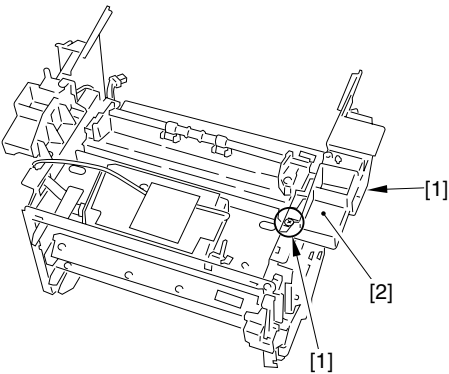

F-3-216

### 3.5.5.9 Removing the Plate

0007-7867

- 1) Remove the connector [1] of the ECNT board.
- 2) Remove the 3 screws [2] and then removes the plate [3].

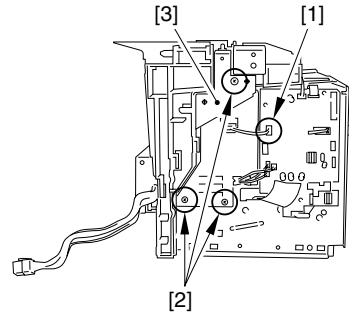

F-3-217

### 3.5.5.10 Removing the Left Frame

0007-7868

- 1) Remove the cable [1] from the cable guide.
- 2) Remove the 2 screws [2], and remove the left frame [3].

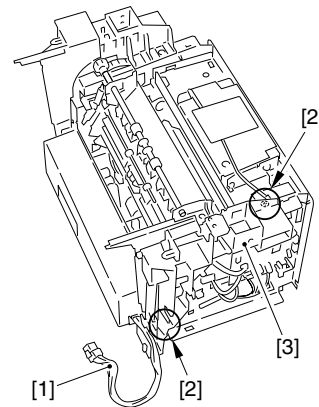

F-3-218

### 3.5.5.11 Removing the Power

#### Supply Shield Plate 0007-7869

- 1) Remove the 5 screws [1] to remove the power supply shield plate [2].

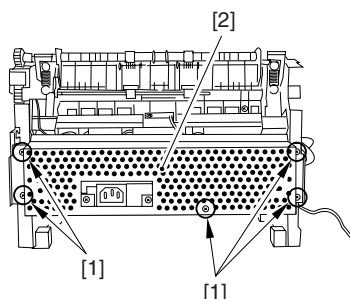

F-3-219

### 3.5.5.12 Removing the Power

#### Supply Assembly 0007-7870

- 1) Remove the 3 screws [1].
- 2) Remove the 4 connectors [2] as well as the flat cable [3] on the ECNT board.

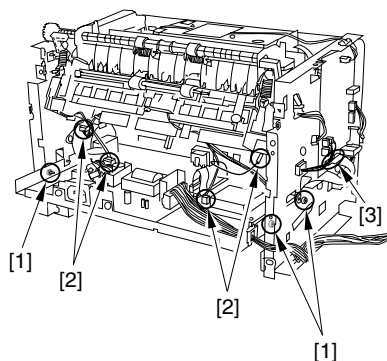

F-3-220

- 3) As you remove the bosses on both sides [1], lower the front part of the power supply assembly [2]. Then pull it to remove the power supply assembly.

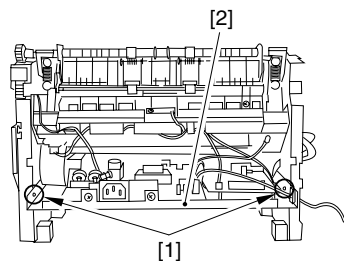

F-3-221

### 3.5.5.13 Removing the Manual

#### Pickup Solenoid 0007-7871

- 1) Place the main unit down on its front face (so that the interior of the main unit is easily visible).
- 2) Remove the cable [1] from the cable guide.
- 3) Remove the screw [2] to remove the manual pickup solenoid [3].

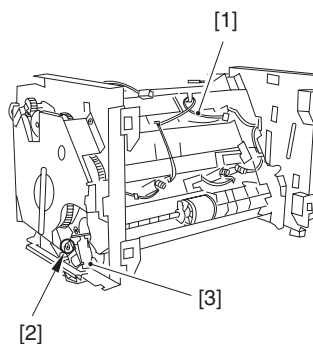

F-3-222

### 3.5.6 Main Motor

#### 3.5.6.1 Removing the Cassette 0002-7570

1) Remove the cassette by holding the cassette handle.

#### 3.5.6.2 Removing the right cover 0007-7780

1) Open the front cover [1], and remove the 2 screws [2] on the front side.

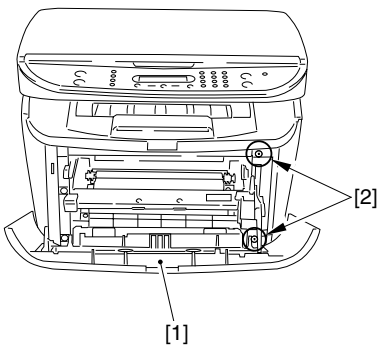

F-3-223

2) Remove the 2 screws [1] on the back side, and remove the right cover [2].

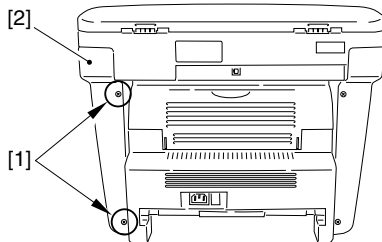

F-3-224

#### 3.5.6.3 Removing the left cover 0007-7781

1) Open the front cover [1], and remove the 2 screws [2] on the front side.

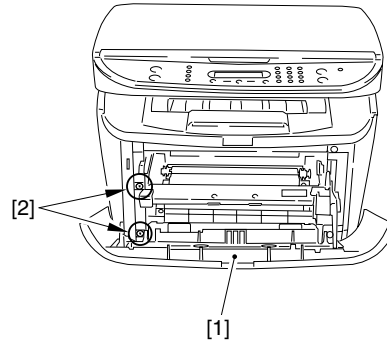

F-3-225

2) Remove the 2 screws [1] on the back side, and remove the left cover [2].

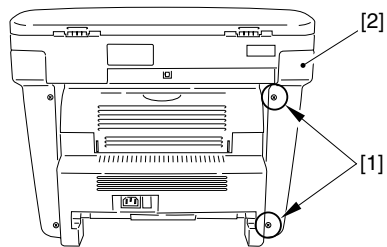

F-3-226



### 3.5.6.4 Removing the front cover

0007-7782

- 1) Open the front cover [1] and remove the arm claws [2] to disengage the connection.
- 2) Remove the shafts on both sides [3] while warping the shaft arms inside, and remove the front cover.

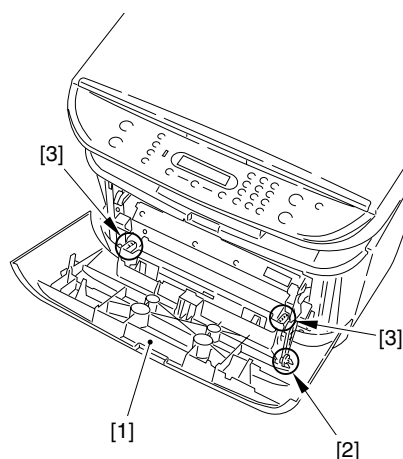

F-3-227

### 3.5.6.5 Removing the rear cover

0007-7783

- 1) Opening the face-up cover [1], and then lower the fixing pressure release levers [2] on both sides and release the pressure.
- 2) Remove 2 screws [3].
- 3) Remove the rear cover [4] as you pull it toward you.

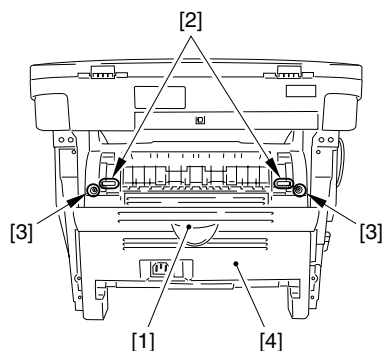

F-3-228

### 3.5.6.6 Removing the Scanner Unit

0007-7784

- 1) Remove the connector [1] and the flat cable [2] on the ECNT board, and remove the screw [3]. (Remove the flat cable from the core.)
- 2) Remove the 2 screws [4] and the 2 pins [5] on the right and left sides.

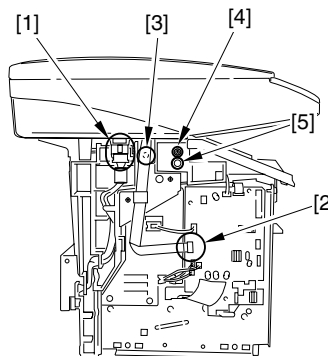

F-3-229

- 3) Remove the 2 screws on the back [1]. Slide the scanner unit [2] to the back; then, remove it by lifting it.

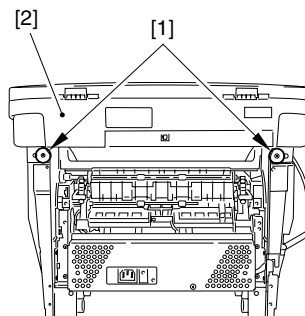

F-3-230

### 3.5.6.7 Removing the Top Cover

0007-7785

- 1) Remove the 2 screws [1], and remove the Top cover [2].

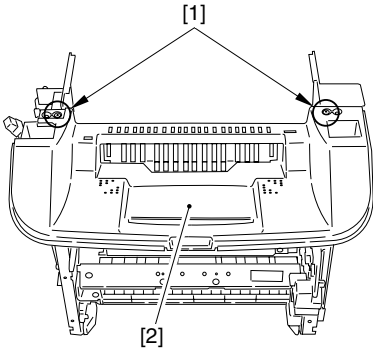

F-3-231

### 3.5.6.8 Removing the Right Frame

0007-7786

- 1) Remove the 3 screws [1], and remove the right frame [2].

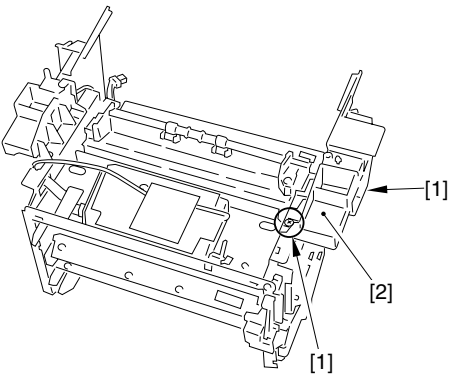

F-3-232

### 3.5.6.9 Removing the Plate

0007-7788

- 1) Remove the connector [1] of the ECNT board.
- 2) Remove the 3 screws [2] and then removes the plate [3].

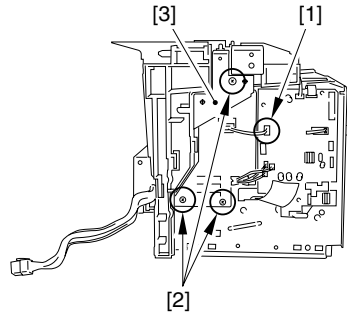

F-3-233

### 3.5.6.10 Removing the Left Frame

0007-7789

- 1) Remove the cable [1] from the cable guide.
- 2) Remove the 2 screws [2], and remove the left frame [3].

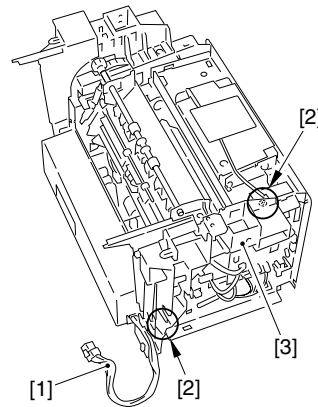

F-3-234

### 3.5.6.11 Removing the Power

#### Supply Shield Plate

0007-7792

- 1) Remove the 5 screws [1] to remove the power supply shield plate [2].

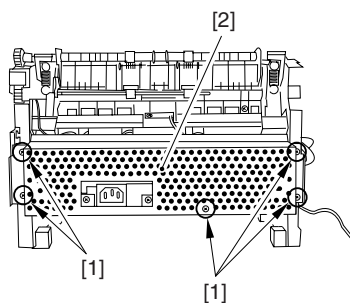

F-3-235

### 3.5.6.12 Removing the Power

#### Supply Assembly

0007-7793

- 1) Remove the 3 screws [1].
- 2) Remove the 4 connectors [2] as well as the flat cable [3] on the ECNT board.

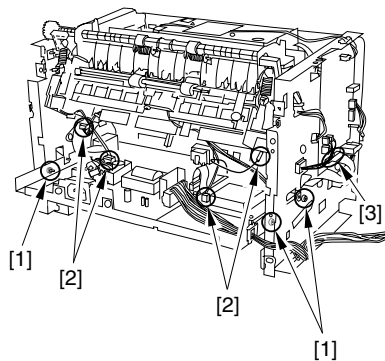

F-3-236

- 3) As you remove the bosses on both sides [1], lower the front part of the power supply assembly [2]. Then pull it to remove the power supply assembly.

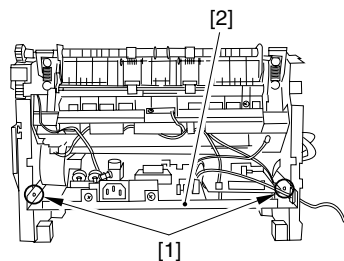

F-3-237

### 3.5.6.13 Removing the Main

#### Motor

0007-7794

- 1) Place the main unit down on its front face (so that the interior of the main unit is easily visible).
- 2) Remove the 2 screws [1] to remove the main motor [2].

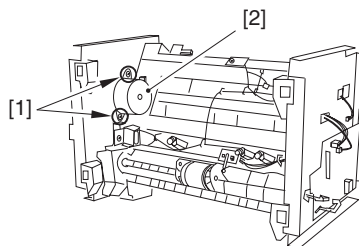

F-3-238

### 3.5.7 Gear Unit

#### 3.5.7.1 Removing the Cassette [0002-7571](#)

1) Remove the cassette by holding the cassette handle.

#### 3.5.7.2 Removing the right cover [0007-7775](#)

1) Open the front cover [1], and remove the 2 screws [2] on the front side.

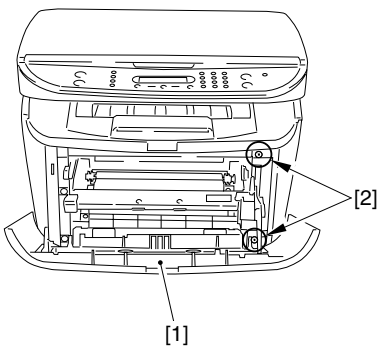

F-3-239

2) Remove the 2 screws [1] on the back side, and remove the right cover [2].

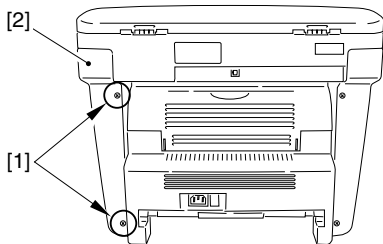

F-3-240

#### 3.5.7.3 Removing the Gear Unit [0007-7778](#)

1) Remove the 2 screws [1], and detach the drive plate (small) [2].

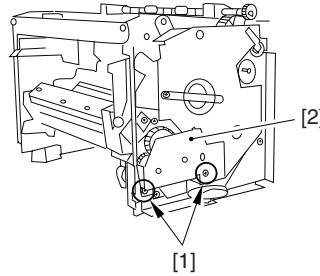

F-3-241

2) Remove the 2 gears [1].

3) While freeing the claw, detach the gear unit [2].

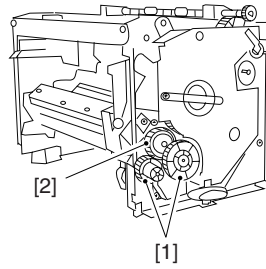

F-3-242

## 3.6 FIXING SYSTEM

### 3.6.1 Fixing Film Unit

#### 3.6.1.1 Removing the Cassette 0002-7190

- 1) Remove the cassette by holding the cassette handle.

#### 3.6.1.2 Removing the right cover 0007-7729

- 1) Open the front cover [1], and remove the 2 screws [2] on the front side.

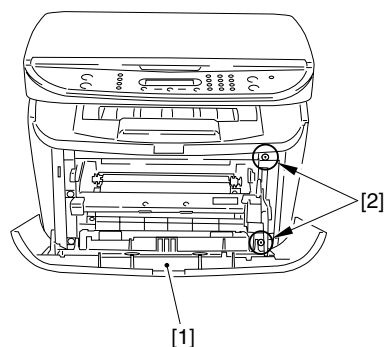

F-3-243

- 2) Remove the 2 screws [1] on the back side, and remove the right cover [2].

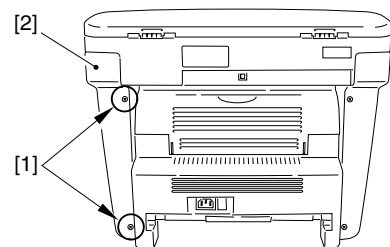

F-3-244

#### 3.6.1.3 Removing the left cover 0007-7730

- 1) Open the front cover [1], and remove the 2 screws [2] on the front side.

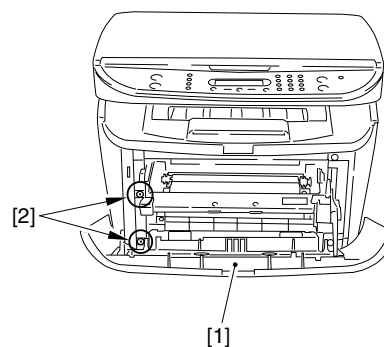

F-3-245

- 2) Remove the 2 screws [1] on the back side, and remove the left cover [2].

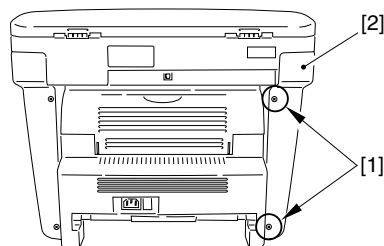

F-3-246

### 3.6.1.4 Removing the front cover 0007-7732

- 1) Open the front cover [1] and remove the arm claws [2] to disengage the connection.
- 2) Remove the shafts on both sides [3] while warping the shaft arms inside, and remove the front cover.

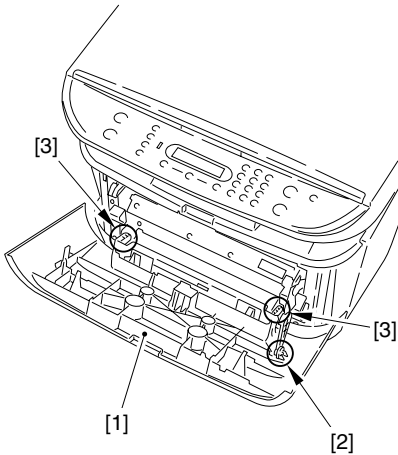

F-3-247

### 3.6.1.5 Removing the rear cover 0007-7733

- 1) Opening the face-up cover [1], and then lower the fixing pressure release levers [2] on both sides and release the pressure.
- 2) Remove 2 screws [3].
- 3) Remove the rear cover [4] as you pull it toward you.

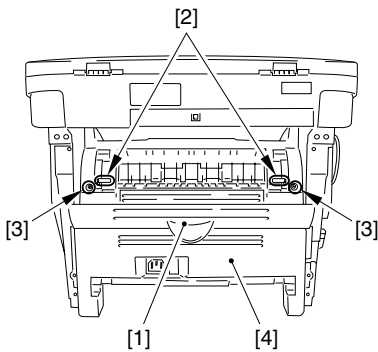

F-3-248

### 3.6.1.6 Removing the Scanner

Unit 0007-7734

- 1) Remove the connector [1] and the flat cable [2] on the ECNT board, and remove the screw [3]. (Remove the flat cable from the core.)
- 2) Remove the 2 screws [4] and the 2 pins [5] on the right and left sides.

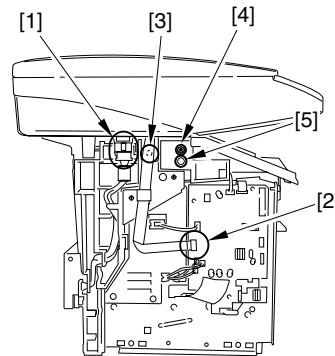

F-3-249

- 3) Remove the 2 screws on the back [1]. Slide the scanner unit [2] to the back; then, remove it by lifting it.

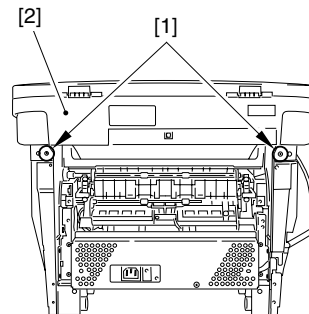

F-3-250

### 3.6.1.7 Removing the Top Cover

0007-7735

- 1) Remove the 2 screws [1], and remove the Top cover [2].

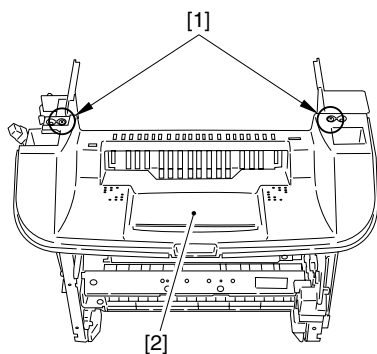

F-3-251

### 3.6.1.8 Removing the Right Frame

0007-7737

- 1) Remove the 3 screws [1], and remove the right frame [2].

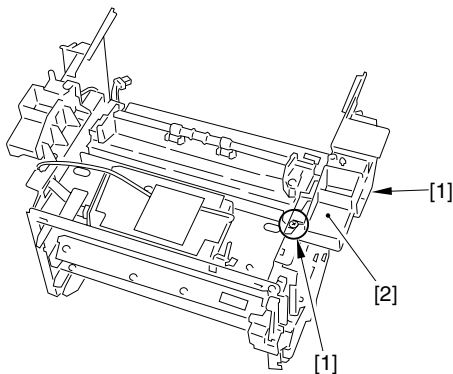

F-3-252

### 3.6.1.9 Removing the Plate

0007-7740

- 1) Remove the connector [1] of the ECNT board.
- 2) Remove the 3 screws [2] and then removes the plate [3].

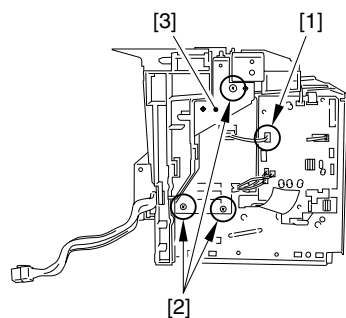

F-3-253

### 3.6.1.10 Removing the Left Frame

0007-7744

- 1) Remove the cable [1] from the cable guide.
- 2) Remove the 2 screws [2], and remove the left frame [3].

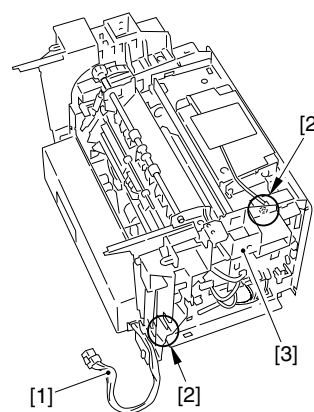

F-3-254

### 3.6.1.11 Removing the Power

#### Supply Shield Plate

0007-7748

- 1) Remove the 5 screws [1] to remove the power supply shield plate [2].

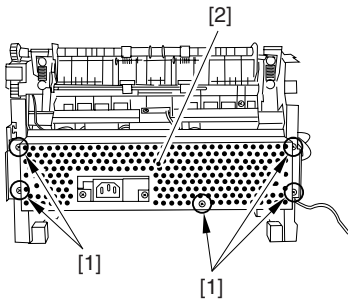

F-3-255

### 3.6.1.12 Removing the Fixing

#### Film Unit

0007-7749

- 1) Remove the 2 screws [1] and take off the Fixing cover [2].

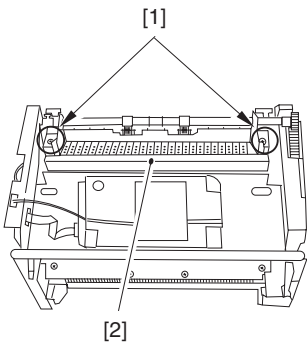

F-3-256

- 2) Remove the 2 screws [1]. Remove the Fixing entrance guide [2] by sliding it sideways back and forth.

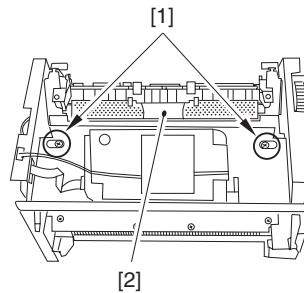

F-3-257

- 3) Disengage the connector [1] of the power supply board.
- 4) Remove the grounding springs and the pressure springs [2] on both sides.
- 5) Remove the pressure plates [3] on both sides.

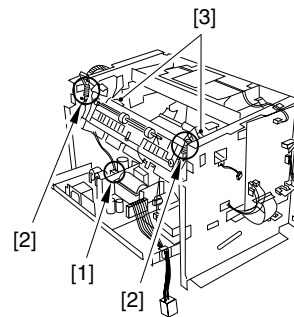

F-3-258



- 6) While holding the left and right frames [2] of the Fixing film unit [1], lift it up at an angle and remove it.

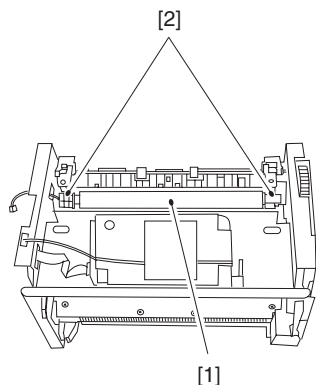

F-3-259

### 3.6.2 Fixing Pressure Roller

#### 3.6.2.1 Removing the Cassette [0002-7191](#)

- 1) Remove the cassette by holding the cassette handle.

#### 3.6.2.2 Removing the right cover [0007-7754](#)

- 1) Open the front cover [1], and remove the 2 screws [2] on the front side.

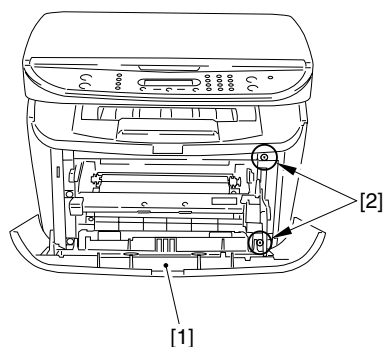

F-3-260

- 2) Remove the 2 screws [1] on the back side, and remove the right cover [2].

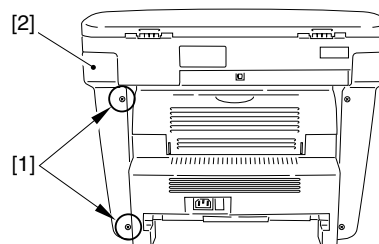

F-3-261

#### 3.6.2.3 Removing the left cover [0007-7756](#)

- 1) Open the front cover [1], and remove the 2 screws [2] on the front side.

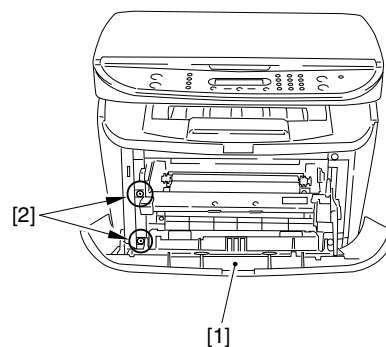

F-3-262

- 2) Remove the 2 screws [1] on the back side, and remove the left cover [2].

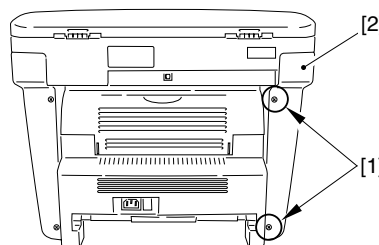

F-3-263

### 3.6.2.4 Removing the front cover

0007-7757

- 1) Open the front cover [1] and remove the arm claws [2] to disengage the connection.
- 2) Remove the shafts on both sides [3] while warping the shaft arms inside, and remove the front cover.

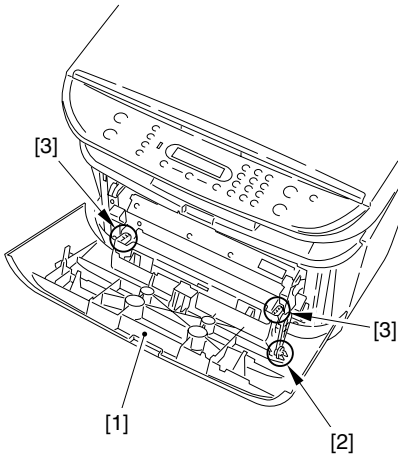

F-3-264

### 3.6.2.5 Removing the rear cover

0007-7758

- 1) Opening the face-up cover [1], and then lower the fixing pressure release levers [2] on both sides and release the pressure.
- 2) Remove 2 screws [3].
- 3) Remove the rear cover [4] as you pull it toward you.

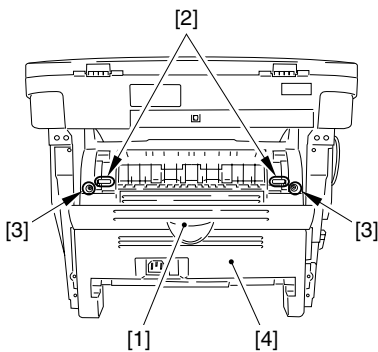

F-3-265

### 3.6.2.6 Removing the Scanner Unit

0007-7760

- 1) Remove the connector [1] and the flat cable [2] on the ECNT board, and remove the screw [3]. (Remove the flat cable from the core.)
- 2) Remove the 2 screws [4] and the 2 pins [5] on the right and left sides.

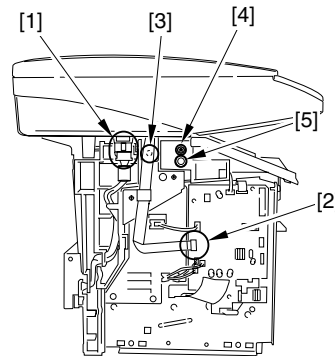

F-3-266

- 3) Remove the 2 screws on the back [1]. Slide the scanner unit [2] to the back; then, remove it by lifting it.

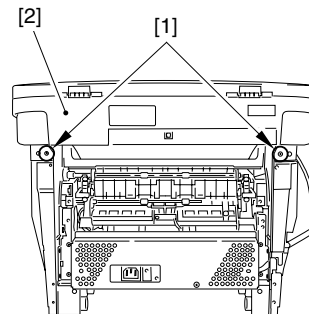

F-3-267

### 3.6.2.7 Removing the Top Cover

0007-7761

- 1) Remove the 2 screws [1], and remove the Top cover [2].

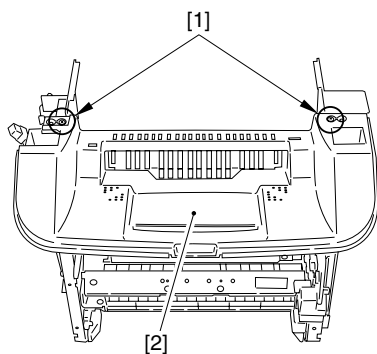

F-3-268

### 3.6.2.8 Removing the Right Frame

0007-7762

- 1) Remove the 3 screws [1], and remove the right frame [2].

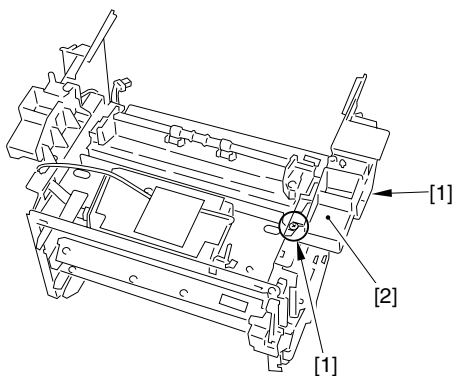

F-3-269

### 3.6.2.9 Removing the Plate

0007-7763

- 1) Remove the connector [1] of the ECNT board.
- 2) Remove the 3 screws [2] and then remove the plate [3].

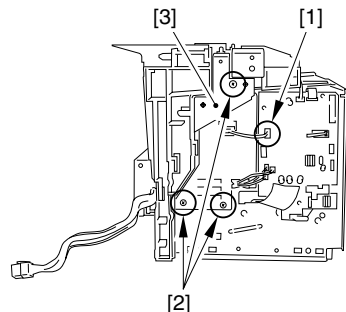

F-3-270

### 3.6.2.10 Removing the Left Frame

0007-7764

- 1) Remove the cable [1] from the cable guide.
- 2) Remove the 2 screws [2], and remove the left frame [3].

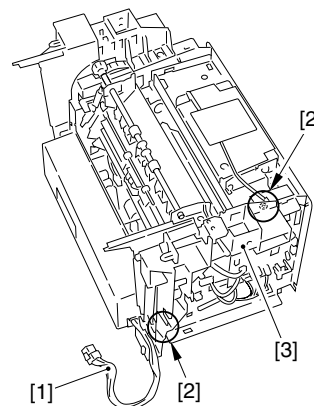

F-3-271

### 3.6.2.11 Removing the Power

#### Supply Shield Plate 0007-7765

- 1) Remove the 5 screws [1] to remove the power supply shield plate [2].

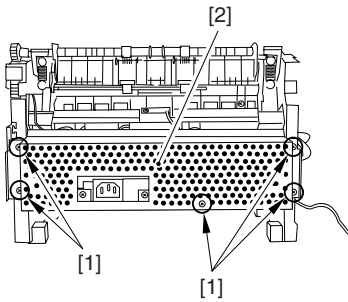

F-3-272

### 3.6.2.12 Removing the Fixing

#### Film Unit 0007-7766

- 1) Remove the 2 screws [1] and take off the Fixing cover [2].

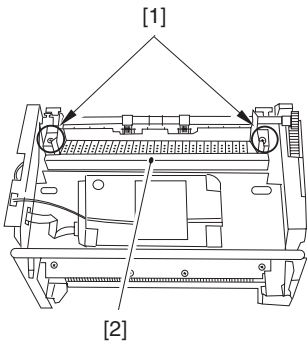

F-3-273

- 2) Remove the 2 screws [1]. Remove the Fixing entrance guide [2] by sliding it sideways back and forth.

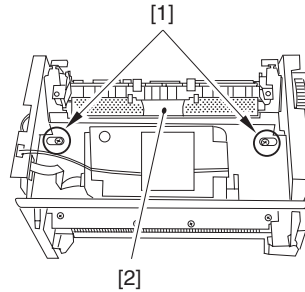

F-3-274

- 3) Disengage the connector [1] of the power supply board.
- 4) Remove the grounding springs and the pressure springs [2] on both sides.
- 5) Remove the pressure plates [3] on both sides.

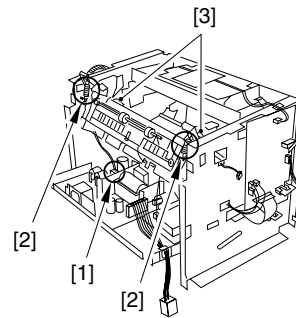

F-3-275

6) While holding the left and right frames [2] of the Fixing film unit [1], lift it up at an angle and remove it.

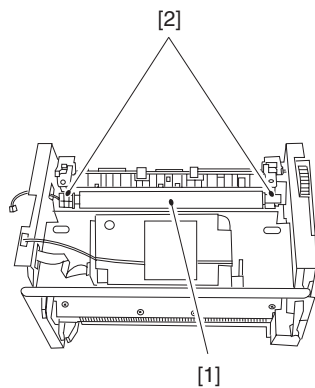

F-3-276

3) Hold the shorter shaft [2] of the Fixing pressure roller [1] and lift it up at an angle to remove it from the bushing. Remove the Fixing pressure roller by sliding it.

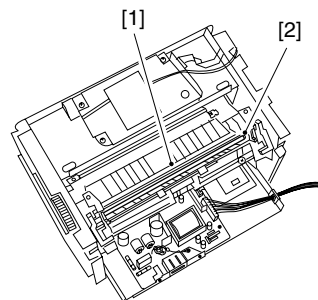

F-3-278

### 3.6.2.13 Removing the Fixing Pressure Roller

0007-7767

- 1) Remove the gear [1] by disengaging the claw.
- 2) Take out the boss of the bushing [2], turn it, and remove the bushing.

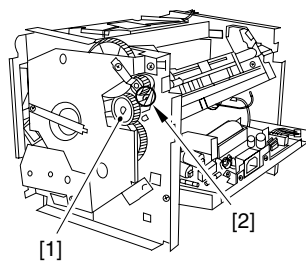

F-3-277



---

# Chapter 4    MAINTENANCE                   AND INSPECTION

---





# Contents

4.1 Periodically Replaced Parts.....	4- 1
4.1.1Parts Requiring Periodical Replacement.....	4- 1
4.2 Consumables .....	4- 2
4.2.1Consumable.....	4- 2
4.3 Periodical Service.....	4- 3
4.3.1Items Requiring Scheduled Servicing .....	4- 3
4.4 Cleaning .....	4- 4
4.4.1Items Requiring Cleaning.....	4- 4
4.4.2Cleaning Method (external covers).....	4- 5
4.4.3Cleaning Method (scanning unit).....	4- 5
4.4.4Cleaning Method (printer unit) .....	4- 6
4.5 Lubrications.....	4- 7
4.5.1Areas Requiring Application of Grease .....	4- 7
4.5.2Delivery Idler Gear.....	4- 8
4.5.3Fixing Drive Transmission Gear .....	4- 9
4.5.4Large Gear Bushing R.....	4- 9
4.5.5Large Gear.....	4- 10
4.5.6Feed Gear .....	4- 10
4.5.7Internal Gear.....	4- 11
4.5.8Large Gear Deceleration Gear/Plate R.....	4- 12
4.5.9Main Motor .....	4- 13
4.5.10Drive Releasing Arm.....	4- 14
4.5.11FU Delivery Roller.....	4- 15
4.5.12Pickup Idler Gear .....	4- 16
4.5.13Feed Deceleration Gear .....	4- 16
4.5.14Fixing Deceleration Gear .....	4- 17
4.5.15FD Delivery Roller.....	4- 18
4.5.16Large Gear Bushing F .....	4- 18
4.5.17Pressure roller.....	4- 19
4.5.18Cassette Pickup Roller .....	4- 19
4.5.19CCD Shaft .....	4- 20
4.5.20Wheel Shaft .....	4- 20



## 4.1 Periodically Replaced Parts

---

### 4.1.1 Parts Requiring Periodical Replacement

0003-0867

The machine does not have parts that require periodical replacement.

## 4.2 Consumables

---

### 4.2.1 Consumable

0007-6479

T-4-1

<b>Work by</b>	<b>Item</b>	<b>Interval (guide)</b>
User	Cartridge EP-27	When toner in the toner cartridge being used has run out.
Service Technician	None	

## 4.3 Periodical Service

---

### 4.3.1 Items Requiring Scheduled Servicing

0003-0865

The machine does not have items that require scheduled servicing.

## 4.4 Cleaning

### 4.4.1 Items Requiring Cleaning

0007-6484

T-4-2

Work by	Item	Intervals
User	External covers	As needed (when soiled)
	Platen glass	When smears appear on image scanned from the platen glass
	Rear surface of the platen glass cover	When smears appear on image scanned from the platen glass
Service technician	Cassette pickup roller	When paper pickup performance has lowered
	Cassette separation pad	When paper separation performance has lowered
	Feed roller	When paper feed performance has lowered
	Transfer charging roller	When the back of paper tends to become soiled; or, when a white spot appears in the images at intervals of about 46 mm
	Static eliminator	When dots appear in images
	Paper feed guide	When the back of paper tends to become soiled
	Fixing entrance guide	When paper tends to become soiled; when a black line appears vertically at irregular intervals; when paper jams; when paper wrinkles
	Fixing film	When images tend to become soiled at intervals of about 57 mm
	Fixing pressure roller	When the back of paper shows traces at intervals of about 64 mm; when fixing faults occur; when paper jams; when paper wrinkles

**⚠** Before starting cleaning work, be sure to turn off the power and disconnect the power plug to avoid fires and electric shocks.

#### 4.4.2 Cleaning Method (external covers)

0003-2119

Moisten a soft cloth with water or solution of mild detergent, making sure it is well wrung; then, wipe the soiling. If you have used detergent, be sure to remove its residue using a soft, moist cloth. After removing all soiling, dry wipe the area with a soft, dry cloth.

#### 4.4.3 Cleaning Method (scanning unit)

0007-6487

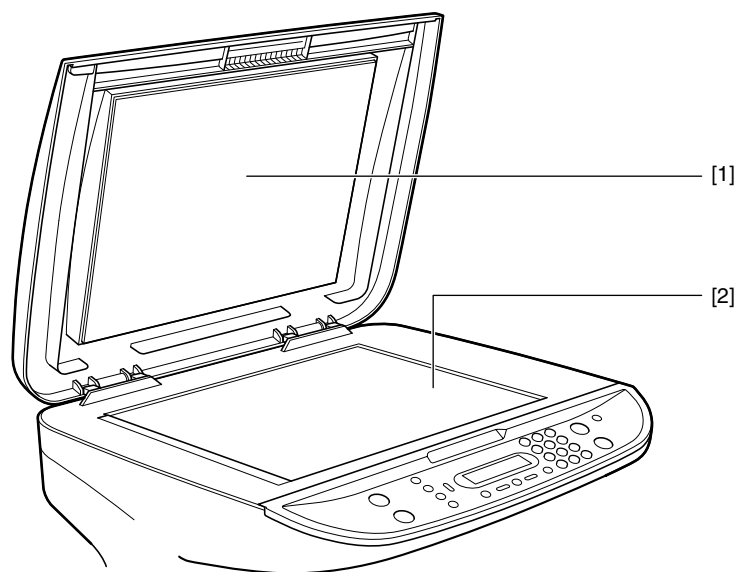

F-4-1

**[1] Rear surface of the platen glass cover**

Open the platen glass cover and wipe any dirt off with a soft, dry cloth.

**[2] Platen glass**

Open the platen glass cover and wipe any dirt off with a soft, dry cloth.

## 4.4.4 Cleaning Method (printer unit)

0007-9060

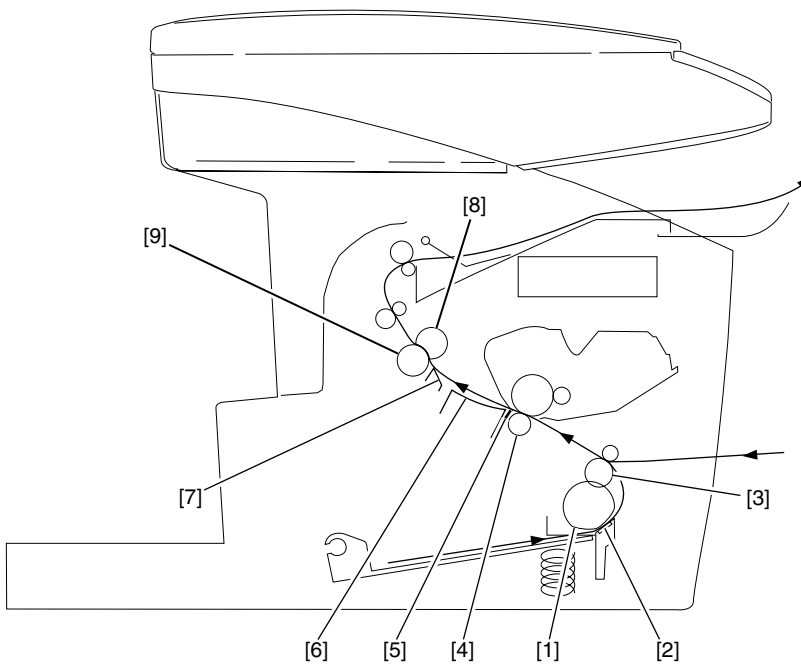

F-4-2

**[1] Cassette Pickup Roller**

Use lint-free paper to remove soiling.

**[2] Cassette Separation Pad**

Use lint-free paper to remove soiling.

**[3] Feed Roller**

Use lint-free paper to remove soiling.

**[4] Transfer Charging Roller**

Use lint-free paper to remove toner and paper lint.

**⚠** - Do not touch the sponge area of the transfer charging roller to avoid soiling the back of paper or white spots in the images.

- Never use solvent.

- If the soiling cannot be removed using lint-free paper or the roller is deformed, replace the roller.

**[5] Static Eliminator**

Remove dust and paper lint using a brush.

**[6] Paper Feed Guide**

Use lint-free paper to remove soiling.

**[7] Fixing Entrance Guide**

Use lint-free paper moistened with isopropyl alcohol to remove the soiling.

**[8] Fixing Film**

Use lint-free paper to remove soiling.

**[9] Fixing Pressure Roller**

Use lint-free paper to remove soiling.



## 4.5 Lubrications

### 4.5.1 Areas Requiring Application of Grease

0007-9175

The machine has areas that require grease to permit smooth movement of parts or ensure good electrical conductivity. If you have replaced a part in these areas or if you have removed the grease, be sure to apply grease.

#### Printer unit

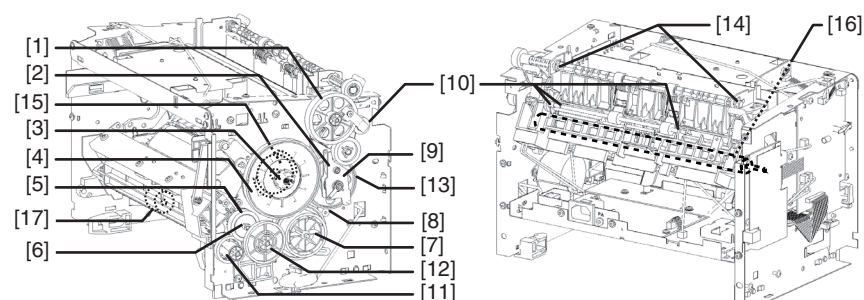

F-4-3

T-4-3

- |  |                               |
|--|-------------------------------|
| [1] Delivery idler gear                  | [10] FU delivery roller       |
| [2] Fixing drive transmission gear       | [11] Pickup idler gear        |
| [3] Large gear bushing R                 | [12] Feed deceleration gear   |
| [4] Large gear                           | [13] Fixing deceleration gear |
| [5] Feed gear                            | [14] FD delivery gear         |
| [6] Internal gear                        | [15] Large gear bushing F     |
| [7] Large gear deceleration gear/Plate R | [16] Pressure roller          |
| [8] Main motor                           | [17] Cassette pickup roller   |
| [9] Drive releasing arm                  |                               |

### Scanner unit

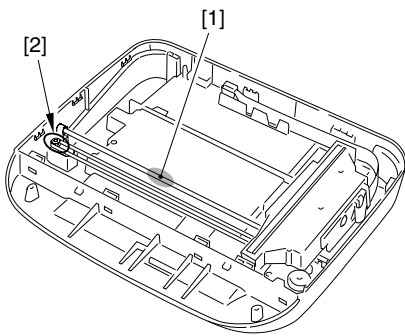

F-4-4

T-4-4

[1] CCD shaft

[2] Wheel shaft

### 4.5.2 Delivery Idler Gear

0002-7926

Area of application: [1]

Grease: MOLYKOTE EM-50L

Amount: 40 +/-10 mg

Location of application:

- 2 locations on gear support shaft in opposition
- spread in axial direction

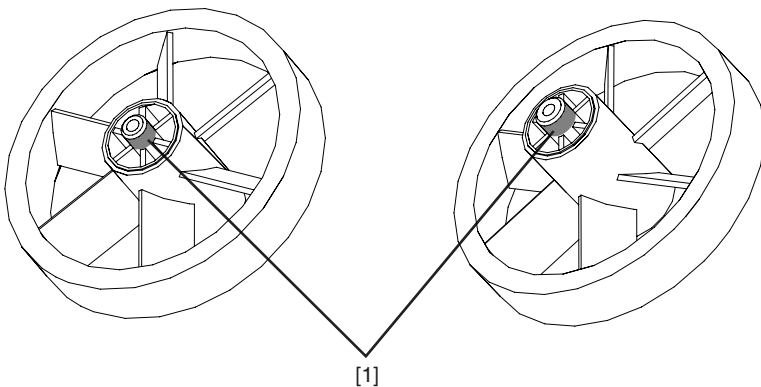

F-4-5

### 4.5.3 Fixing Drive Transmission Gear

0002-7929

Area of application: [1]

Grease: MOLYKOTE EM-50L

Amount: 10 +/-5 mg

Location of application:

- 2 locations on gear butting ribs in opposition
- spread in circumferential direction over a length of 1/4 or more

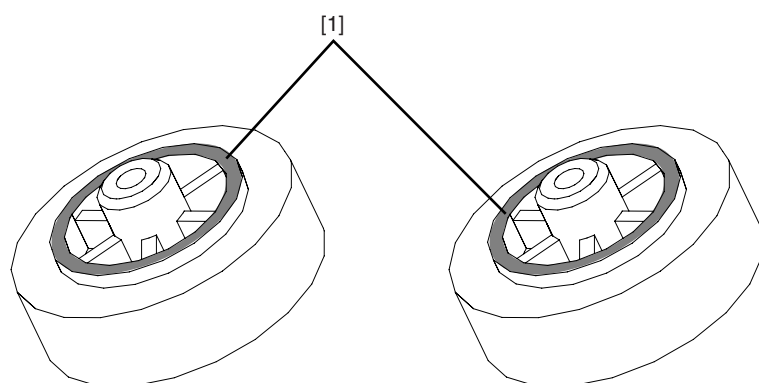

F-4-6

### 4.5.4 Large Gear Bushing R

0002-7930

Area of application: [1]

Grease: MOLYKOTE EM-50L

Amount: 10 +/-5 mg

location of application:

- wall surface on inner circumferential side of bushing
- spread in circumferential direction over a length of 1/2 or more

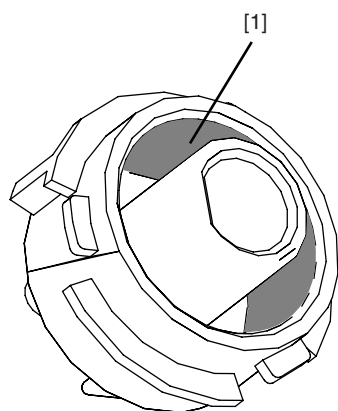

F-4-7

### 4.5.5 Large Gear

0002-7933

Area of application: [1]

Grease: MOLYKOTE EM-50L

Amount: 20 +/-10 mg

Location of application:

- rib against which gear is butted
- spread in circumferential direction over a length of 1/2 or more

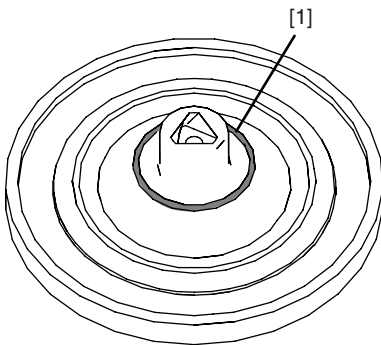

F-4-8

### 4.5.6 Feed Gear

0002-7935

Area of application: [1]

Grease: MOLYKOTE EM-50L

Amount: 10 +/-5 mg

Location of application:

- 1 location on boss engaging with internal gear
- spread in axial direction

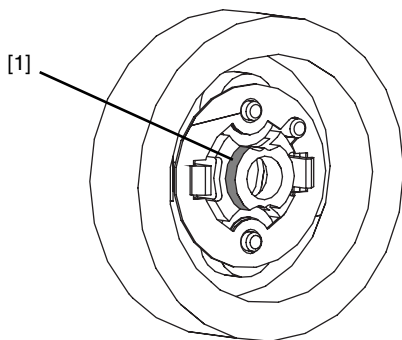

F-4-9

## 4.5.7 Internal Gear

0002-7937

Area of application: [1]

Grease: MOLYKOTE EM-50L

Amount: 40 +/-10 mg

Location of application:

- 5 teeth or more of internal gear in opposition
- 2 locations in circumferential direction

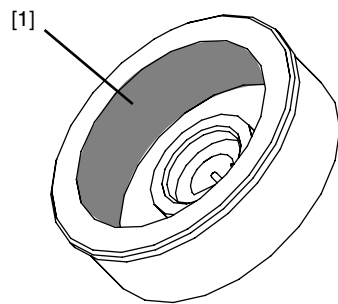

F-4-10

## 4.5.8 Large Gear Deceleration Gear/Plate R

0002-7938

Area of application: [1]

Grease: MOLYKOTE EM-50L

Amount: 40 +/-10 mg

Location of application:

- 5 teeth or more (covering entire small-dia tooth area)

Area of application: [2]

Grease: MOLYKOTE EM-50L

Amount: 10 +/-5 mg

Location of application

- support shaft of plate R (sliding surface against large gear deceleration gear)

- spread in axial direction

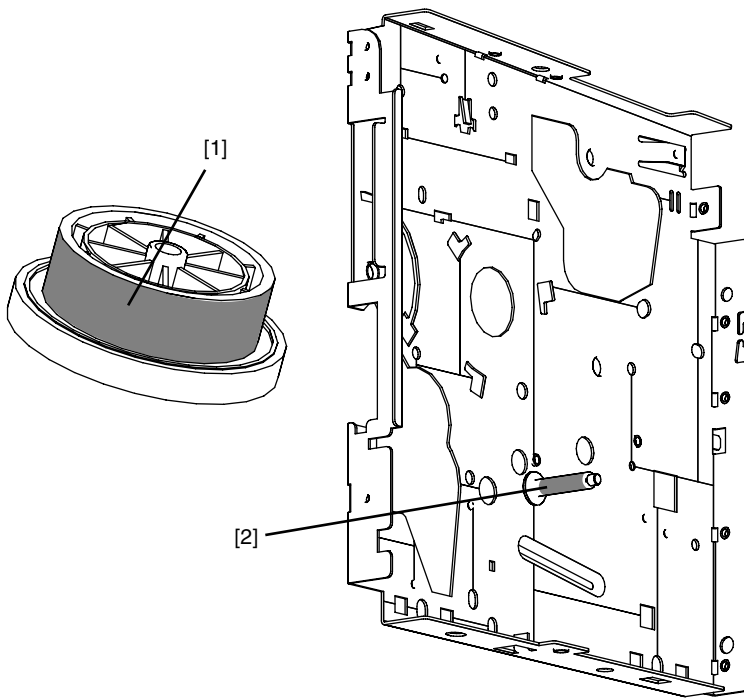

F-4-11

## 4.5.9 Main Motor

0002-7939

Area of application: [1]

Grease: MOLYKOTE EM-50L

Amount: 40 +/-10 mg

Location of application:

- 5 teeth or more (covering entire gear width)

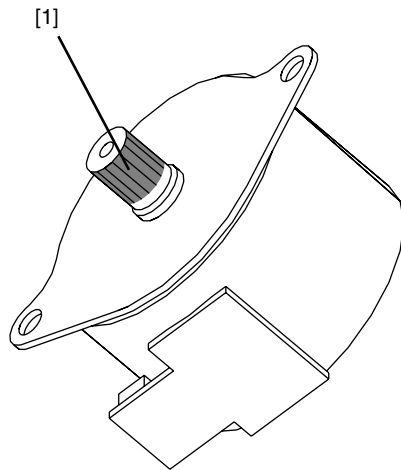

F-4-12

## 4.5.10 Drive Releasing Arm

0002-7940

Area of application: [1]

Grease: MOLYKOTE EM-50L

Amount: 10 +/-5 mg

Location of application:

- 4 locations on sliding surface against gear support shaft of drive releasing arm

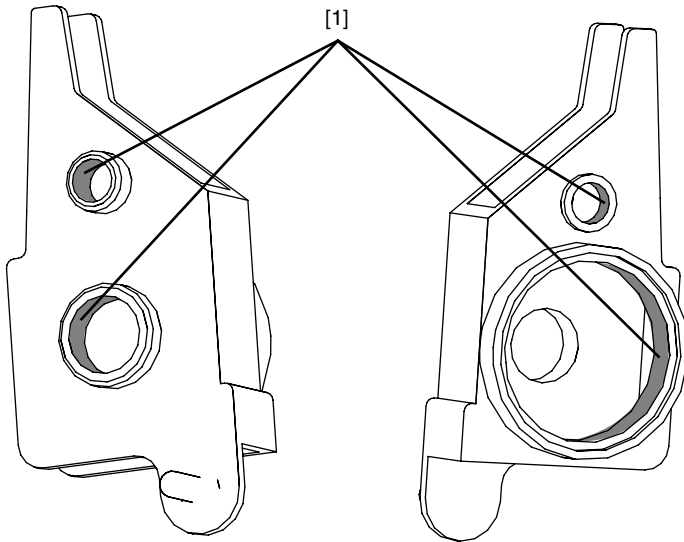

F-4-13



## 4.5.11 FU Delivery Roller

0002-7942

Area of application: [1]

Grease: MOLYKOTE 41

Amount: 10 +/-5 mg

Location of application:

- edge of FU delivery roller shaft (sliding surface against FU grounding spring)

Area of application: [2]

Grease: MOLYKOTE EM-50L

Amount: 10 +/-5 mg

Location of application:

- sliding surface between FU delivery roller shaft and FU delivery roller bushing

Area of application: [3]

Grease: MOLYKOTE EM-50L

Amount: 10 +/-5 mg

Location of application:

- sliding surface between FU delivery roller shaft and delivery guide (FU delivery roller shaft stop rib)

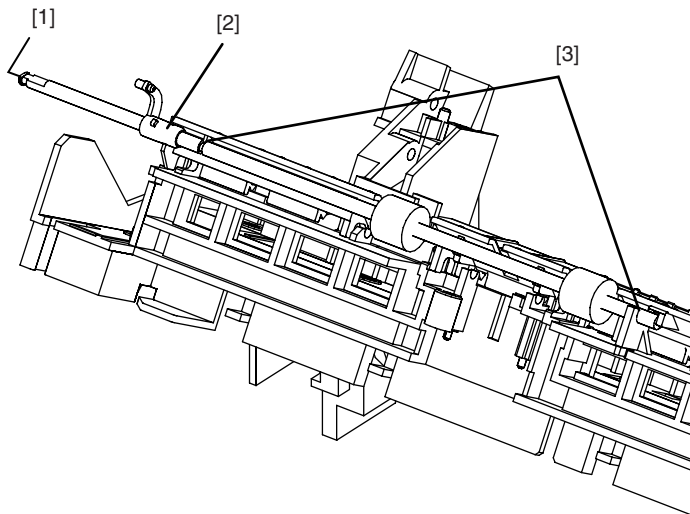

F-4-14

### 4.5.12 Pickup Idler Gear

0002-7944

Area of application: [1]

Grease: MOLYKOTE EM-50L

Amount: 10 +/-5 mg

Location of application:

- 2 locations on pickup idler gear support shaft
- 5 teeth or more (covering entire large-diameter tooth surface of pickup idler gear)

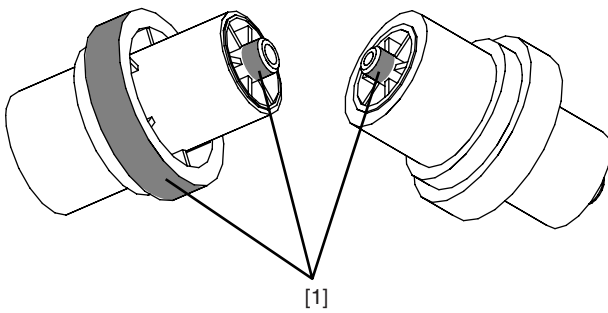

F-4-15

### 4.5.13 Feed Deceleration Gear

0002-7946

Area of application: [1]

Grease: MOLYKOTE EM-50L

Amount: 10 +/-5 mg

Location of application:

- 2 locations on feed deceleration gear support shaft
- spread in axial direction

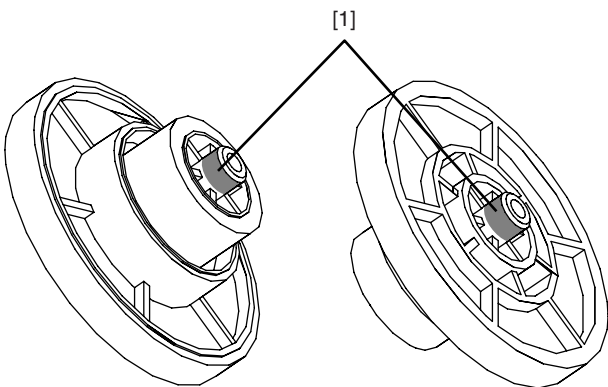

F-4-16

## 4.5.14 Fixing Deceleration Gear

0002-7954

Area of application: [1]

Grease: MOLYKOTE EM-50L

Amount: 40 +/-10 mg

Location of application

- 5 teeth or more (covering entire surface of fixing deceleration gear; small-diameter teeth)

Area of application: [2]

Grease: MOLYKOTE EM-50L

Amount: 10 +/-5 mg

Location application:

- tip of feed deceleration gear butting rib in circumferential direction over a length of 1/2 or more

Area of location: [3]

Grease: MOLYKOTE EM-50L

Amount: 10 +/-5 mg

Location of application:

- sliding surface against plate R of fixing deceleration gear in circumstantial direction over a length of 1/2 or more

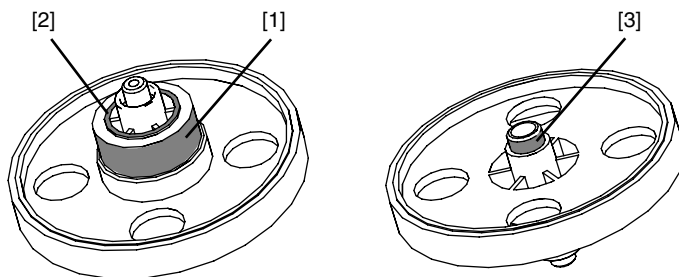

F-4-17

### 4.5.15 FD Delivery Roller

0002-7948

Area of application: [1]

Grease: MOLYKOTE EM-50L

Amount: 30 +/-5 mg

Location of application

- entire sliding surface against FD delivery bushing

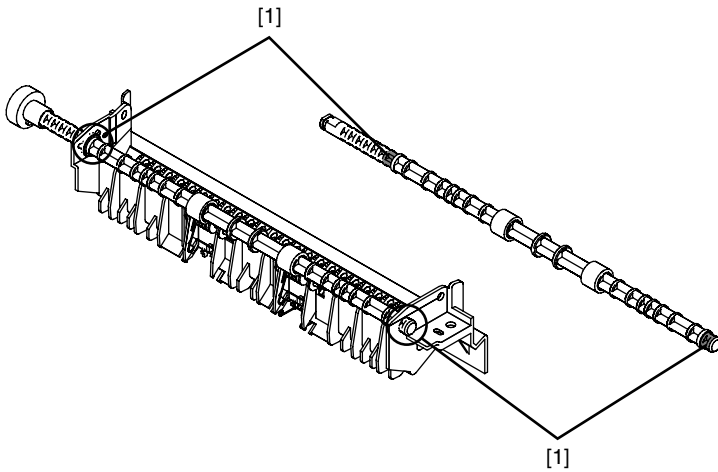

F-4-18

### 4.5.16 Large Gear Bushing F

0002-7950

Area of application: [1]

Grease: MOLYKOTE EM-50L

Amount: 10 +/-5 mg

Location of application:

- entire sliding surface against large gear support shaft

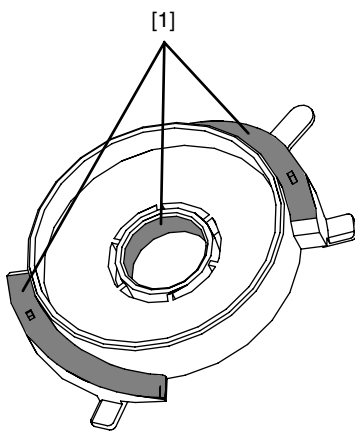

F-4-19

### 4.5.17 Pressure roller

0002-7953

Area of application: [1]

Grease: MOLYKOTE 41

Amount: 10 +/-10 mg

Location of application:

- edge of pressure roller shaft (sliding surface against contact spring F)

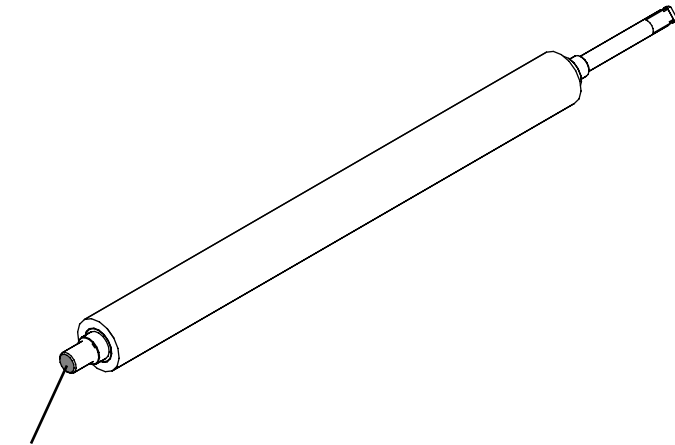

[1]  
F-4-20

### 4.5.18 Cassette Pickup Roller

0003-6451

Area of application: [1]

Grease: MOLYKOTE EM-50L

Amount: approx. 10 mg

Location of application:

- cassette pickup roller shaft, main unit frame (around the bushing), and the area where contacts the cassette pickup bushing

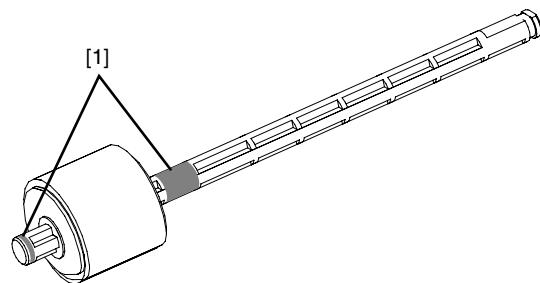

[1]  
F-4-21

## 4.5.19 CCD Shaft

0003-2409

Area of application: [1]

Grease: MOLYKOTE EM-50L

Amount: suitable amount

Location of application:

- part of CCD shaft where contacts the CCD unit (all the faces in the shaft direction)

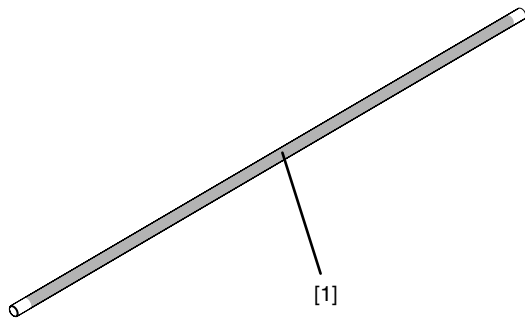

F-4-22

## 4.5.20 Wheel Shaft

0007-8738

Area of application: [1]

Grease: MOLYKOTE EM-50L

Amount: suitable amount

Location of application:

- part of wheel shaft where contacts the wheel unit

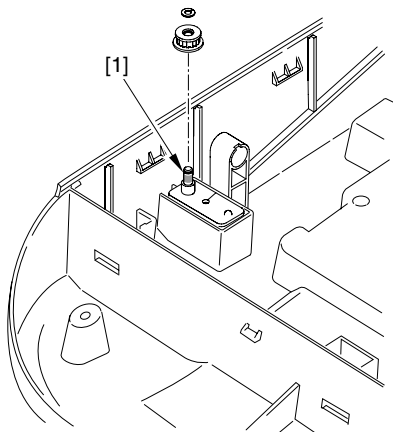

F-4-23

---

# Chapter 5 TROUBLE- SHOOTING

---





---

---

# Contents

5.1 Phenomenon Table .....	5- 1
5.1.1 Symptoms .....	5- 1
5.2 Countermeasure .....	5- 2
5.2.1 Image Faults .....	5- 2
5.2.1.1 Partially Blank/Streaked .....	5- 2
5.2.2 Malfunction .....	5- 2
5.2.2.1 Control Panel-Related .....	5- 2
5.2.2.2 Malfunction/Faulty Detection .....	5- 2
5.2.3 Printing/Scanning .....	5- 3
5.2.3.1 Faulty Printing/Scanning Result .....	5- 3
5.2.4 Jam (Main Unit) .....	5- 3
5.2.4.1 Jam when feeding paper from a cassette .....	5- 3
5.2.4.2 The machine identifies a jam when its power is turned off and then on with paper in its manual feed section .....	5- 3
5.3 Measurement and Adjustment .....	5- 4
5.3.1 Basic Adjustments .....	5- 4
5.3.1.1 Items of Adjustment .....	5- 4
5.4 Service Tools .....	5- 5
5.4.1 Special Tools .....	5- 5
5.5 Error Code .....	5- 6
5.5.1 Outline .....	5- 6
5.5.1.1 Error Code Outline .....	5- 6
5.5.2 Service Error Code .....	5- 6
5.5.2.1 Unique Remedies Service Error Codes .....	5- 6
5.5.2.2 E000 Fixing Unit Failure .....	5- 6
5.5.2.3 E100 Laser/Scanner Unit Failure .....	5- 7
5.6 Service Mode .....	5- 8
5.6.1 Outline .....	5- 8
5.6.1.1 Service Data Setting .....	5- 8
5.6.1.2 Service Data Entry Method .....	5- 9
5.6.1.3 Service Data Flowchart .....	5- 9
5.6.2 Service Soft Switch Settings (SSSW) .....	5- 12
5.6.2.1 Outline .....	5- 12
5.6.2.2 SSSW-SW14 .....	5- 13
5.6.3 ROM Management (ROM) .....	5- 14
5.6.3.1 ROM .....	5- 14
5.6.4 Test Mode (TEST) .....	5- 14
5.6.4.1 Overview .....	5- 14
5.6.4.2 DRAM Test .....	5- 16
5.6.4.3 Print Test .....	5- 17
5.6.4.3.1 Faculty Test .....	5- 18



## 5.1 Phenomenon Table

### 5.1.1 Symptoms

0007-8077

T-5-1

Level 1	Symptom
Image Faults	There are vertical black lines or a vertical white line in a solid black image.
Malfunction	When manual paper size is set to envelope, the LCD in standby mode shows ENV. regardless of envelope type.  When paper size is set to A5, paper size error does not occur even if printing is made with other-size paper.
Printing/Scanning	When legal paper is used to copy multiple documents, image at the top of the 2nd document is printed on the bottom of the 1st legal sheet.
Jam (Main Unit)	Jam when feeding paper from a cassette  The machine identifies a jam when its power is turned off and then on with paper in its manual feed section.

For details, see the instructions given as remedial action.

## 5.2 Countermeasure

---

### 5.2.1 Image Faults

#### 5.2.1.1 Partially Blank/Streaked

5.2.1.1.1 There are vertical black lines or a vertical white line in a solid black image.

0007-8083

<Cause>

The vertical black lines are likely to have been caused by the ribs of the heater holder. The vertical white line is likely to have been caused by the thermal fuse (if it corresponds to the location of the fuse).

<Field Remedy>

Select heavy paper mode.

### 5.2.2 Malfunction

#### 5.2.2.1 Control Panel-Related

5.2.2.1.1 When manual paper size is set to envelope, the LCD in standby mode shows ENV.  
regardless of envelope type.

0007-8088

<Cause>

The LCD in standby mode does not support envelop type indications.

<Field Remedy>

Display the User data registration screen or output a User data list to check envelope type.

#### 5.2.2.2 Malfunction/Faulty Detection

5.2.2.2.1 When paper size is set to A5, paper size error does not occur even if printing is made with  
other-size paper.

0007-8091

<Cause>

The printer engine does not support A5 size.

<Field Remedy>

Since image printed on a sheet is A5 size, paper size error does not occur.

Therefore, field remedy is not taken.

## 5.2.3 Printing/Scanning

### 5.2.3.1 Faulty Printing/Scanning Result

5.2.3.1.1 When legal paper is used to copy multiple documents, image at the top of the 2nd document is printed on the bottom of the 1st legal sheet.

0007-8092

<Cause>

If legal paper is used to copy 2 or more documents but paper type is set to other than legal, image data of the 2nd document is sent following the 1st document. Therefore, image at the top of the 2nd document is printed on the bottom of the 1st legal sheet.

<Field Remedy>

Set correct paper type and size.

## 5.2.4 Jam (Main Unit)

5.2.4.1 Jam when feeding paper from a cassette

0007-8093

<Cause>

There are cases where the cassette paper sensor detects paper and feeds it even though the cassette is not in place.

<Field Remedy>

Set the cassette in the designated place.

5.2.4.2 The machine identifies a jam when its power is turned off and then on with paper in its manual feed section

0007-8094

<Cause>

The machine is designed to identify a jam if the manual feed paper sensor is on when it is turned on, as it is not sure whether the paper is set correctly or incorrectly.

<Field Remedy>

Remove the paper, open and close the front cover, and place the paper back in the manual feed section.

## 5.3 Measurement and Adjustment

---

### 5.3.1 Basic Adjustments

#### 5.3.1.1 Items of Adjustment 0003-3366

The machine does not have items that are cited for adjustment.

---

## 5.4 Service Tools

---

### 5.4.1 Special Tools

0007-6537

T-5-2

<b>Tool</b>	<b>Description</b>	<b>Parts No.</b>
Grease (MOLYKOTE EM-50L)	Apply to specified areas.	HY9-0007
Grease (MOLYKOTE EMD-110)	Apply to specified areas.	HY9-0023
Grease (IF-20)	Apply to specified areas.	CK-8006
Grease (MOLYKOTE 41)	Apply to specified areas.	CK-8007

## 5.5 Error Code

### 5.5.1 Outline

#### 5.5.1.1 Error Code Outline

0007-6749

An error code is used to indicate a fault in a machine, and is indicated in the machine's LCD, showing the nature (symptoms) of the fault. Using the error code, the service man can readily find out how to correct the fault by simply referring to the service manual.

An error code may be either of the following two types:

##### Service Error Codes

If a fault calls for a service man for correction, it is indicated as a service man error code in the form of "SYSTEM ERROR E+number."

### 5.5.2 Service Error Code

#### 5.5.2.1 Unique Remedies Service Error Codes

0007-6768

T-5-3

No.	Tx or Rx	Definition
E000	[Rx]	Fixing unit failure
E100	[Rx]	Laser/Scanner unit failure

#### 5.5.2.2 E000 Fixing Unit Failure

0007-6769

##### Cause:

Fixing unit failure.

##### Remedy:

- 1) Turn the power off and on.
- 2) Make sure that the fixing unit and ECNT board (J505) are properly connected.
- 3) Make sure that the fixing unit and power supply board (CN2) are properly connected.
- 4) Make sure connections of the boards (power supply board (CN101), ECNT board (J501, J502)).
- 5) Replace the fixing unit.



### 5.5.2.3 E100 Laser/Scanner Unit Failure

0007-6772

**Cause:**

Laser/Scanner unit failure.

**Remedy:**

- 1) Turn the power off and on.
- 2) Make sure that the Laser/Scanner unit (J801) and ECNT board (J503) are properly connected.
- 3) Make sure that the Laser/Scanner unit and ECNT board (J504) are properly connected.
- 4) Make sure connections of the boards (power supply board (CN101), ECNT board (J501, J502)).
- 5) Replace the Laser/Scanner unit.

## 5.6 Service Mode

---

### 5.6.1 Outline

#### 5.6.1.1 Service Data Setting

0007-6586

The Service mode has the service data items as follows. They can be confirmed or changed by following the menu.

**#SSSW**

Use it to set the document scanning size.

**#NUMERIC**

Do not use.

**#SPECIAL**

Do not use.

**#NCU**

Do not use.

**#FAX**

Do not use.

**#SCAN**

Do not use.

**#PRINT**

Do not use.

**#NETWORK**

Do not use.

**#CODEC**

Do not use.

**#SYSTEM**

Do not use.

**#REPORT**

Use it to output reports on various service data.

**#DOWNLOAD**

Do not use.

**#CLEAR**

Various data are initialized by selecting one of these setting items.

### 5.6.1.2 Service Data Entry Method

0007-6605

You can enter the Service Mode with the following operation.



F-5-1

### 5.6.1.3 Service Data Flowchart

0007-6621

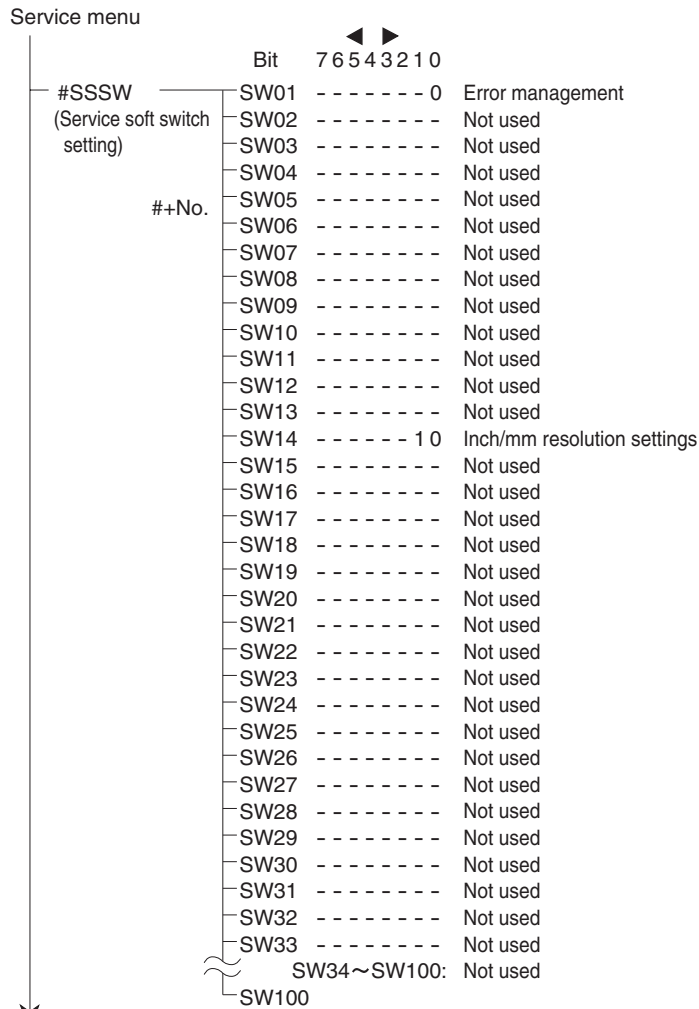

F-5-2

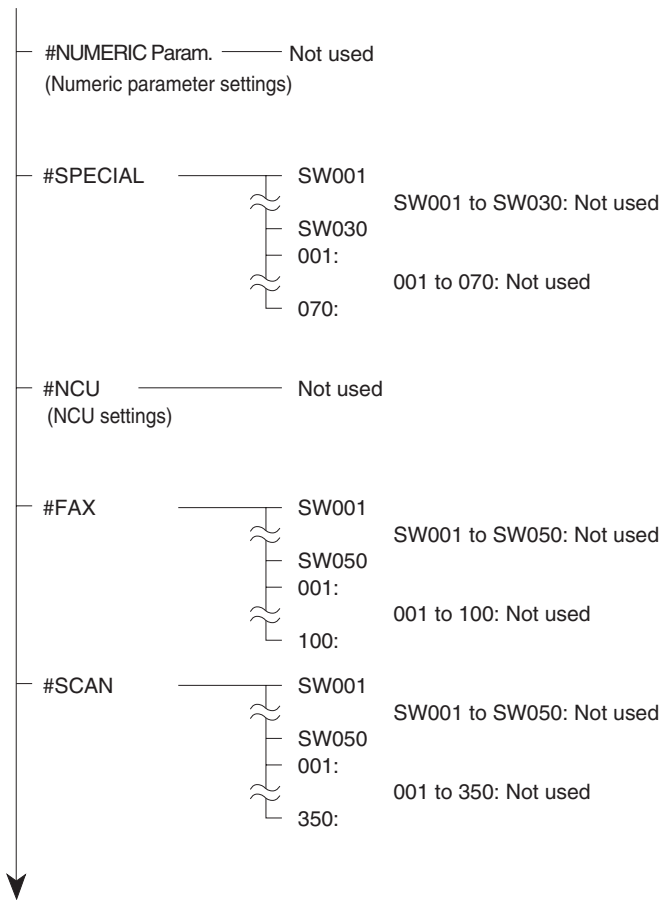

F-5-3

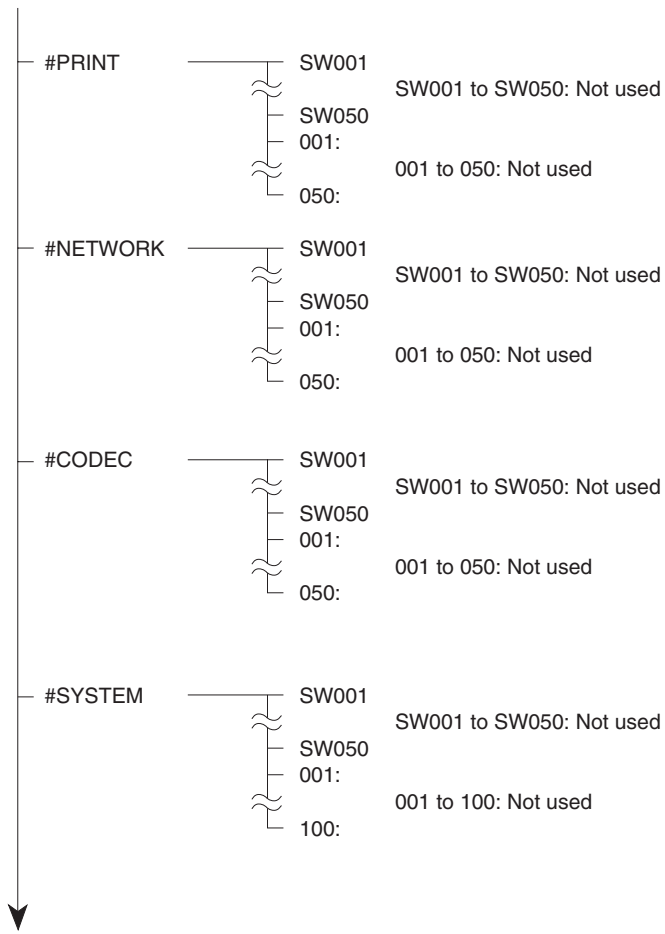

F-5-4

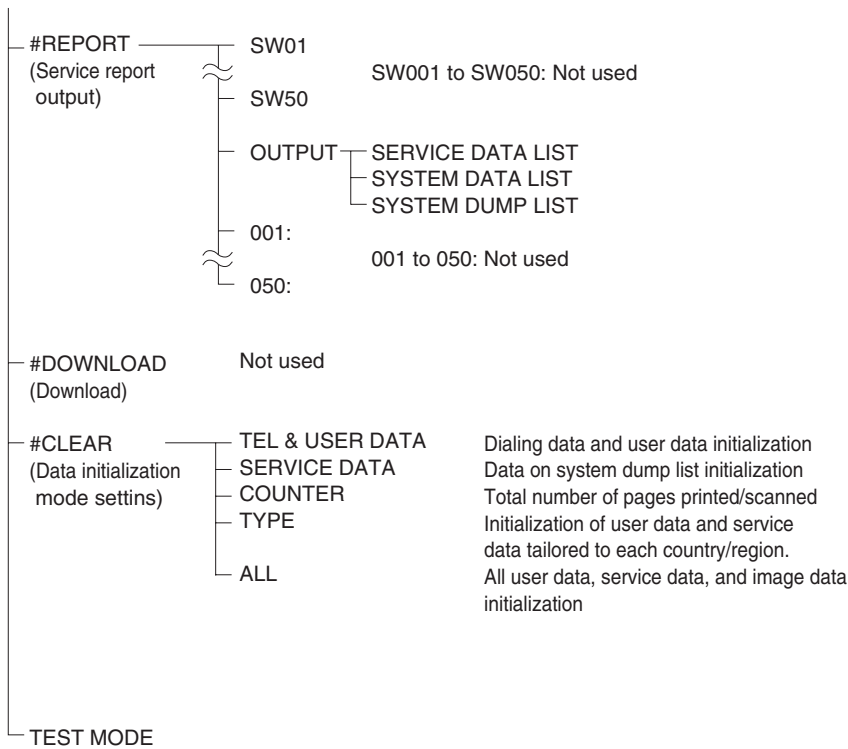

F-5-5

## 5.6.2 Service Soft Switch Settings (SSSW)

### 5.6.2.1 Outline

#### 5.6.2.1.1 Explanation of #SSSW

0007-6628

The items registered and set by each of these switches comprise 8-bit switches. The figure below shows which numbers are assigned to which bits. Each bit has a value of either 0 or 1.

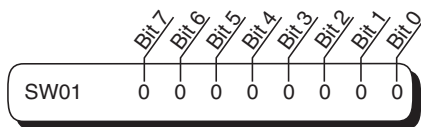

F-5-6

Below are examples showing how to read bit switch tables.

Bit	Function	1	0
0	Service error code	Output	Not Output*
1	Not used	-	-
2	Not used	-	-
3	Not used	-	-
4	Not used	-	-
5	Not used	-	-
6	Not used	-	-
7	Not used	-	-

Indicates that the setting is "1".

Indicates that the setting is "0".

Indicates the default settings.

F-5-7

### 5.6.2.2 SSSW-SW14

#### 5.6.2.2.1 List of Functions

0007-6633

T-5-4

Bit	Function	1	0
0	Document scanning size type	1	0*
1	Document scanning size type	1*	0
2	Not used	-	-
3	Not used	-	-
4	Not used	-	-
5	Not used	-	-
6	Not used	-	-
7	Not used	-	-

#### 5.6.2.2.2 Details of Bit 0 and Bit 1

0007-6650

Set the type of document scanning size (standard paper) to be used.

The following types are set in accordance with the combination of parameters of Bit 0 and Bit 1.

T-5-5

(Bit0, Bit1)= (0, 0) A-series document  
 (0, 1) inch-type document  
 (1, 0) A-series document  
 (1, 1) A-series document

## 5.6.3 ROM Management (ROM)

### 5.6.3.1 ROM

0007-6663

Information such as ROM (program software) version number is displayed on the display.

This mode is for confirmation only, and any entry cannot be made.

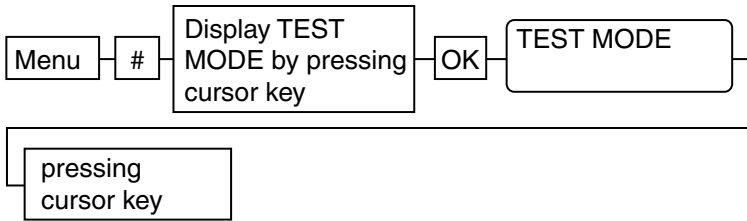

F-5-8

## 5.6.4 Test Mode (TEST)

### 5.6.4.1 Overview

#### 5.6.4.1.1 Test Mode Overview

0007-6666

The following test modes are available from the menu on the display.

#### **D-RAM tests**

Writes data to DRAM image storage areas and reads that data to check operations.

#### **Print test**

Printing a test pattern in the printing area.

#### **FACULTY test**

Testing the sensors and functions of the operation panel.



## 5.6.4.1.2 Test Mode Flowchart

0007-6680

To operate the test mode, after pressing the Menu key, press the # key and select "SERVICE MODE". After this, select "TEST MODE" with the cursor keys, and press the OK key.

Turn OFF and back ON the power to end the Test Mode.

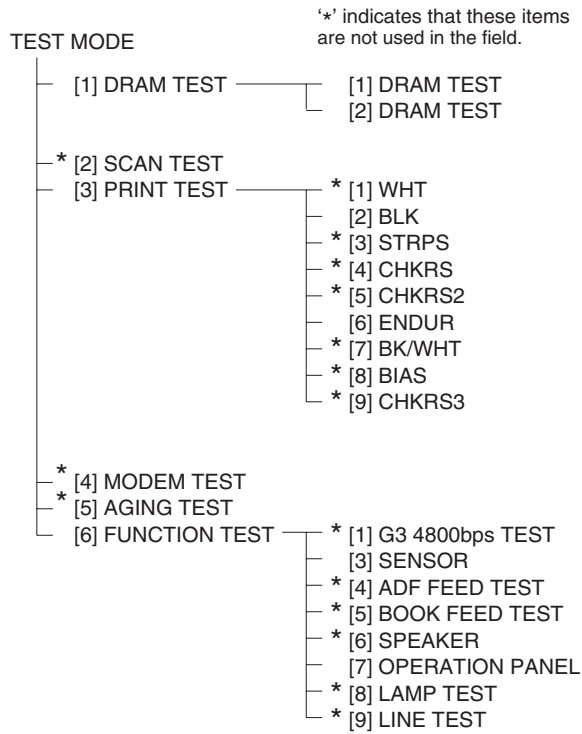

F-5-9

### 5.6.4.2 DRAM Test

#### 5.6.4.2.1 D-RAM Test

0007-6685

D-RAM test menu is selected by pressing the numeric key 1 from the test mode menu. D-RAM Test 1 writes data to the entire D-RAM region and reads it out to check that operations are correct. D-RAM Test 2 just reads data at high speed.

#### Operating

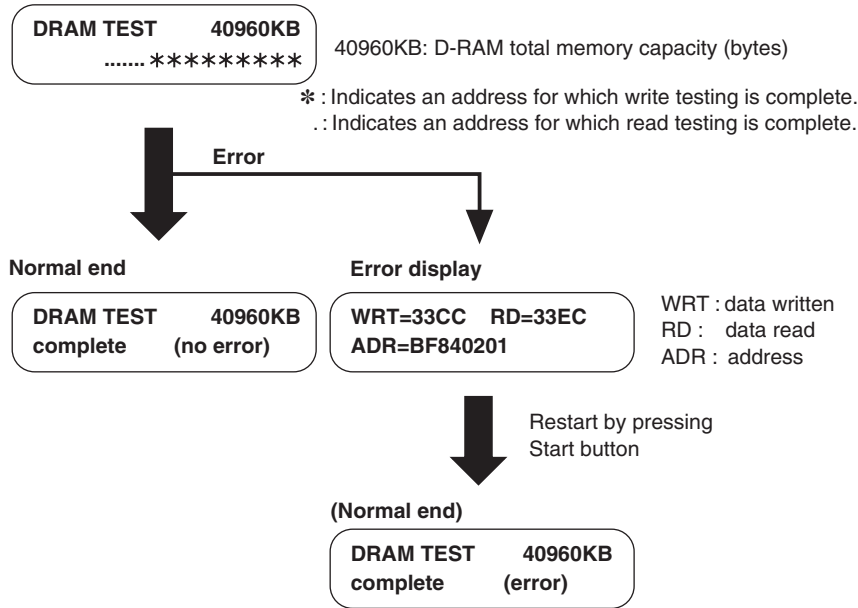

F-5-10

---

**⚠** Before D-RAM test, output all image data in image memory. When D-RAM test is performed, all image data are cleared.

---

---

### 5.6.4.3 Print Test

#### 5.6.4.3.1 PRINT Test

0007-6689

The Print Test menu is selected by pressing the numeric key 3 from the test mode menu.

In this test, various print patterns are output from the printer. As service print patterns, press the numeric key 2 from the Print Test menu to select "3-2: BLACK" or press the numeric key 6 to select "3-6: ENDURANCE". Do not use the other patterns. They are for development and factory use.

Check for white stripes and unevenness on the Black pattern, and check for image shrinkig, stretching, soiling, and black strips on the Endurance pattern.



F-5-11

---

#### **Memo**

After completion of the print test, if the printing was normal, copy a document. If there is any defect in the copied image, there is a defect in the scan section.

---

## 5.6.4.4 Faculty Test

### 5.6.4.4.1 FACULTY Tests

0007-6690

The faculty tests are selected by pressing the numeric key 6 from the test mode menu.  
These tests test the following faculties of this machine.

T-5-6

<b>Test type</b>	<b>Overview</b>
Sensor tests	Test whether the sensors are operating correctly.
Operation panel test	Tests whether the button switches on the control panel are operating correctly.

## 5.6.4.4.2 Sensor Tests

0007-6694

The sensor test is selected by pressing the numeric key 3 from the faculty test menu. In this test, you can check the status of each sensor of this machine in items 1 to 4 on the display.

You can also check if sensors that use actuators and microswitches are operating correctly by moving the actuator or microswitch.

6-3 : SENSOR  
[1]--[4]

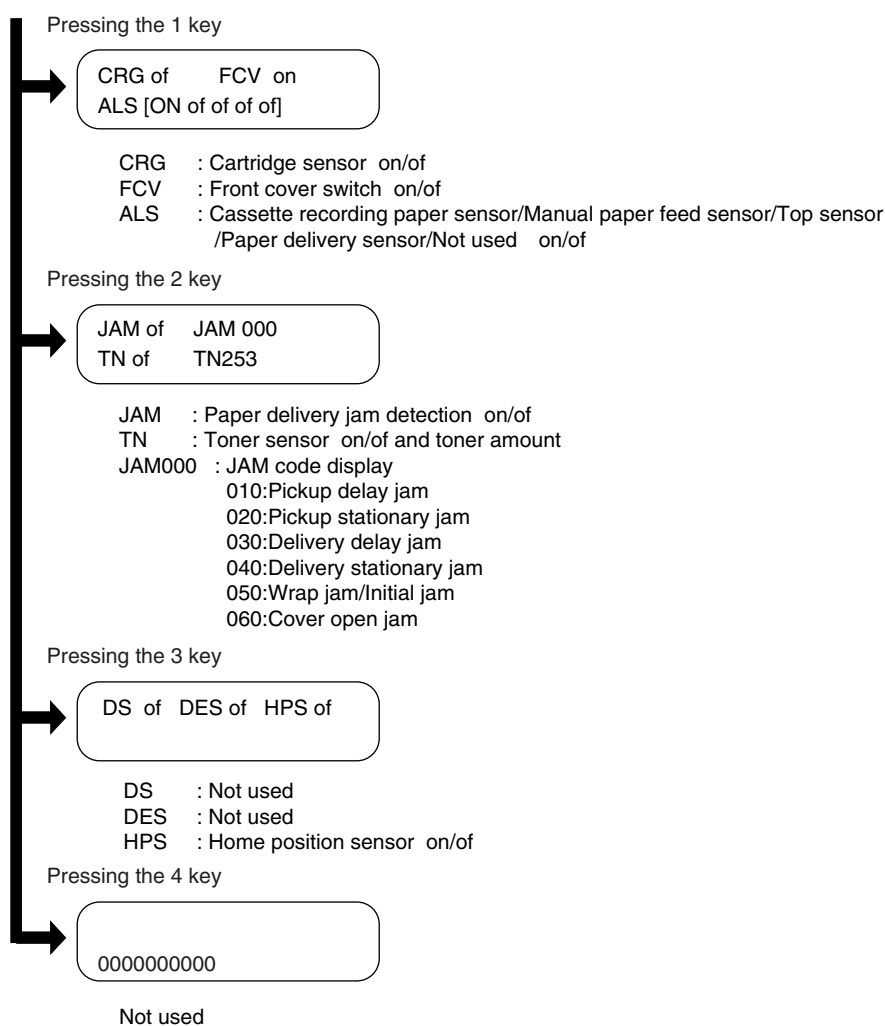

F-5-12

## 5.6.4.4.3 Operation panel tests

0007-6702

The operation panel test is selected by pressing the numeric key 7 from the faculty test menu.

In this test, check that the display, LED lamps and keys on the operation panel are operating correctly.

**Display test**

Pressing the Start key from the operation panel menu, "H" is displayed 20 characters by 2 lines. The next time the Start key is pressed, all the LCD dots are displayed. Check for any LCD dots in the display that are not displayed.

**LED lamp test**

All the lamps on the operation panel light by pressing the Start key after the display test. Check for any LED that does not blink during the test. (However, the Energy Saver key does not go on at this time.)

**Operation key Test**

The operation key test is selected with the Start key after the LED lamp test is done. In this test, a character disappears when its operation key is pressed. The list of characters and their operation keys is as follows. Check to make sure at this time that all characters properly disappear when their operation keys are pressed.

T-5-7

Character	Operation key	Character	Operation key
0-9,*,#	Numeric key	F	Image Quality key
A	Cursor key (+)	G	Enlarge/Reduce key
B	Cursor key (-)	H	Exposure key
C	OK key	I	COPY key
D	Menu key	J	SCAN key
E	Status Monitor key	Q	Energy Saver key
D	Collate/2on1 key		







---

# Chapter 6 APPENDIX

---



# Contents

6.1 Outline of Electrical Components .....	6- 1
6.1.1 Sensor.....	6- 1
6.1.1.1 Arrangement of Sensors and Switches .....	6- 1
6.1.2 PCBs .....	6- 2
6.1.2.1 Arrangement of PCBs.....	6- 2



---

## 6.1 Outline of Electrical Components

---

### 6.1.1 Sensor

#### 6.1.1.1 Arrangement of Sensors and Switches

0007-8186

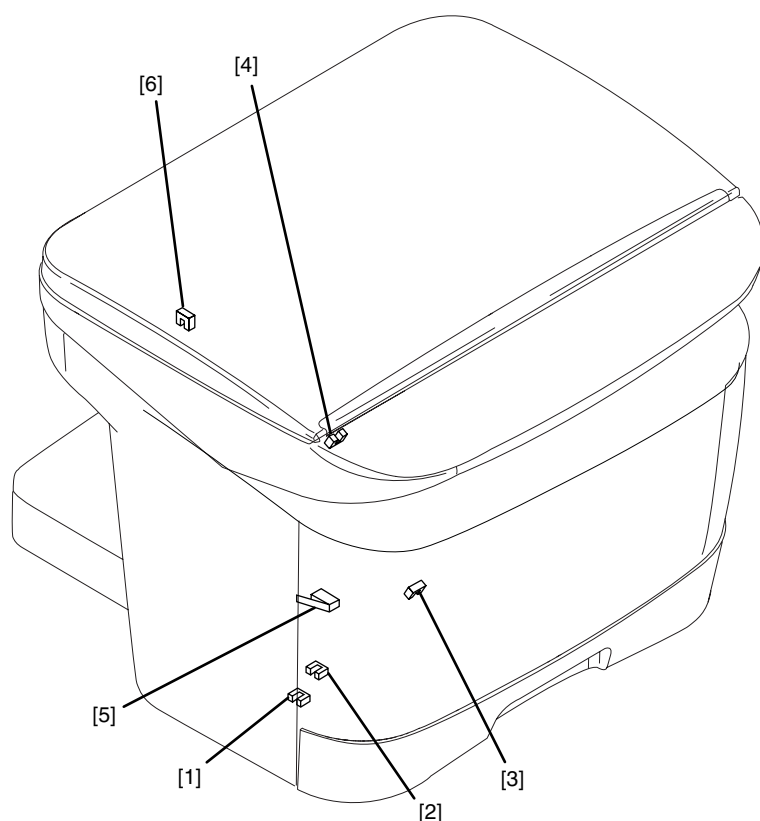

F-6-1

**[1] Cassette Paper Sensor**

Used to detect the presence/absence of paper in the cassette.

**[2] Manual Feed Paper Sensor**

Used to detect the presence/absence of paper in the manual feed section.

**[3] Paper Leading Edge Sensor (top sensor)**

Used to detect the leading/trailing edge of paper being moved.

**[4] Paper Delivery Sensor**

Used to monitor the delivery of paper.

**[5] Front Cover Switch**

Used to detect the state (open/closed) of the front cover.

**[6] CCD Home Position Sensor**

Used to detect the home position of the CCD unit.

## 6.1.2 PCBs

### 6.1.2.1 Arrangement of PCBs

0007-8187

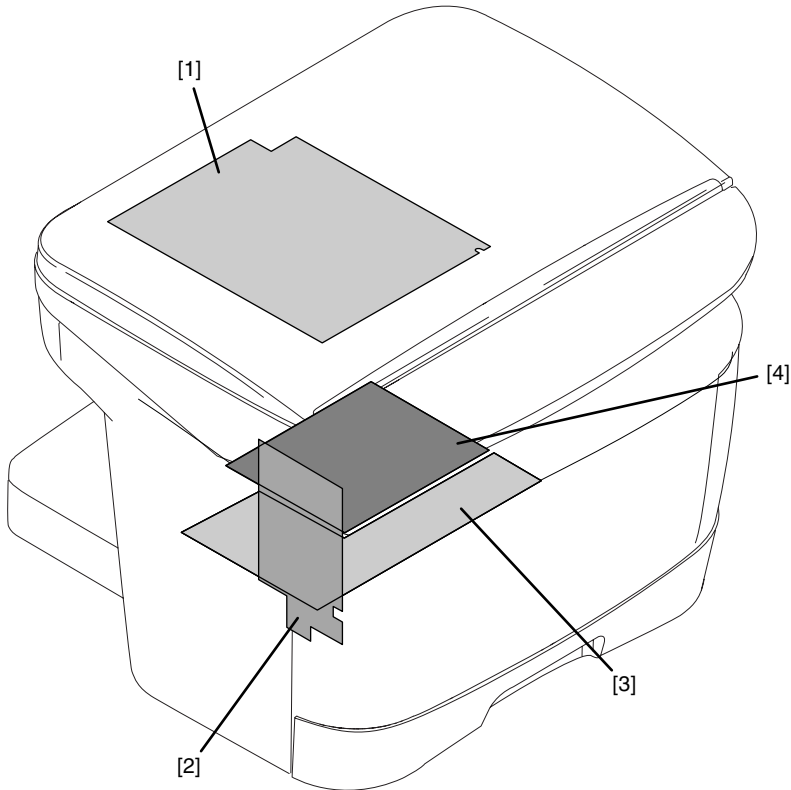

F-6-2

**[1] SCNT Board**

Used to control the whole of the system.

**[2] ECNT Board**

Used to control the operation of the printer unit.

**[3] High-Voltage Power Supply Board**

Used to supply high-voltage power to the printer unit.

**[4] Power Supply Board**

Used to control the supply of power to various components.

Aug 27 2004

**Canon**